



OUTDOOR FIREPLACES

WELCOME

At Woodbridge Fireplace our mission is to design, manufacture, and market quality crafted heating and leisure products for indoor and outdoor enjoyment.

Motivated by homeowners, inspired by contractors, fireplace installers, designers and dealers, and supported by our employees, we are committed to delivering world class products that surpass the expectations of clients and stakeholders alike.

For more information on our company please visit :
www.woodbridgedealer.com

Warm Regards,



Tony James
President

CONTENTS

OUTDOOR GAS FIREPLACES

Algonquin	4
SS-72 (72" Viewing Area)	6
SS-60 (60" Viewing Area)	8
SS-48 (48" Viewing Area)	10
SS-36 (36" Viewing Area)	12
SS-See-Thru (36", 48", 60", 72")	14
SS-PIER (3-Sided)	16
SS-BAY (3-Sided)	18
Fire Feature Enclosure	20
Serpentine	22
Fire Table	24
Square Fire Table	26

INDOOR/OUTDOOR GAS FIREPLACES

SV (36", 48", 60", 72")	28
-------------------------------	----

GAS FIREPITS & BURNER SYSTEMS

Bonfire (32" ϕ)	30
Campfire (26" ϕ)	32
FBB (20" ϕ)	34
Fire Feature	36

GAS LOG SETS

GLO-24 (Outdoor 24")	38
GLO-18 (Outdoor 18")	38

OUTDOOR GAS FIREPLACES

It is in man's nature to crave for warmth and peaceful relaxation beside the fire. The mystic power of fire is captured in Woodbridge outdoor gas fireplaces. Made of heavy gauge polished 304 stainless steel, our outdoor gas fireplaces will stand up to rain, humidity, wind, and snow for for decades, while providing you with many memorable and joyful nights close to a cozy fire.





ALGONQUIN

Make a bold statement



FEATURES

- * Impressive 36" x 32" viewing area with brushed stainless steel interior and 6" border
- * Spectacular reflection of flame that appears on every surface of the interior and fire glass bed
- * Extremely realistic hand detailed log set and various fire glass color options to match any décor
- * On/Off remote control with timer and electronic ignition system with battery back up
- * Complete high grade 304 stainless steel construction to ensure lasting quality



Top view

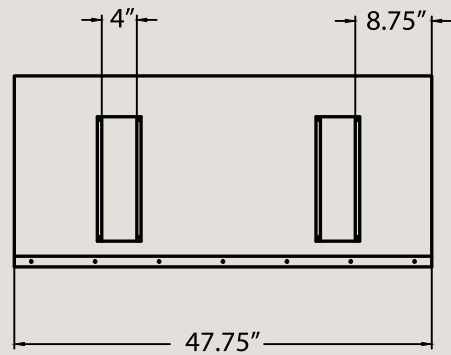

Front view

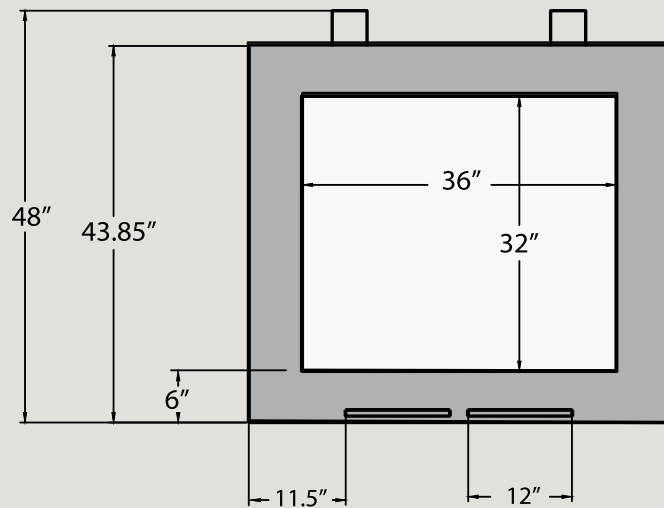

Left side view

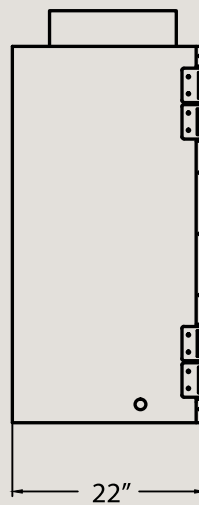

STANDARD FEATURES

- Can be framed in wooden structure and finished with non-combustible materials
- Extremely realistic 7 piece high temperature cement log set.
- Various burner and tray glass media.
- High grade 304 stainless steel construction.
- Dynamic flame reflection from ember bed and brushed stainless steel interior.
- Electronic ignition system with battery back up.
- On/Off remote control or wall switch.

INPUT RATE

ALGONQUIN (NG or LP): 60,000 Btu/h



SS-72

A grand display
of dancing fire



FEATURES

- * 72" wide viewing area with brushed stainless steel interior and 6" border
- * High-grade 304 brushed stainless steel construction to ensure lasting quality
- * Ceramic glass wind baffle
- * On/Off remote control with timer
- * Electronic ignition system with battery back up



Top view

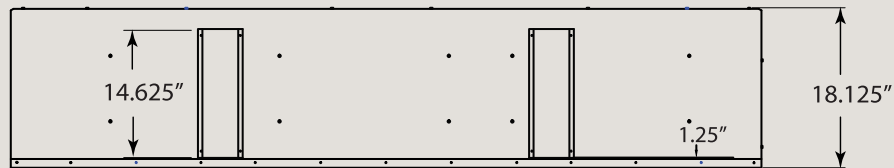

Front view

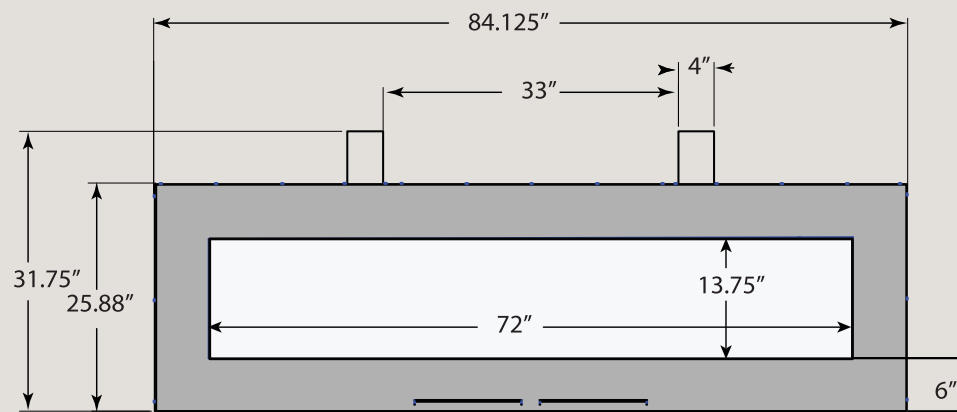

Right side view

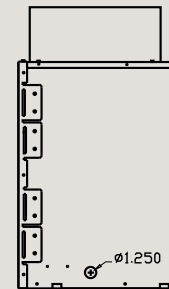

STANDARD FEATURES

- Can be framed in wooden structure and finished with non-combustible materials
- Ceramic glass wind baffle.
- Clear burner and tray glass media.
- High grade 304 stainless steel construction.
- Dynamic flame reflection from ember bed and brushed stainless steel interior.
- Electronic ignition system with battery back up.
- On/Off remote control with timer or wall switch.

AVAILABLE OPTIONS

- Various tray and burner glass media.
- Stainless steel safety screen.
- L.E.D. Light kit with custom media tray.



INPUT RATE

SS-72 (NG or LP): 90,000 Btu/h



SS-60
Extend your outdoor living experience with this show stopping fireplace



FEATURES

- * 60" wide viewing area with brushed stainless steel interior and 6" border
- * High-grade 304 brushed stainless steel construction to ensure lasting quality
- * Ceramic glass wind baffle
- * On/Off remote control with timer
- * Electronic ignition system with battery back up



Top view

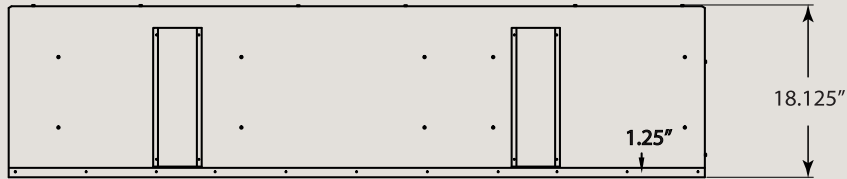

Front view

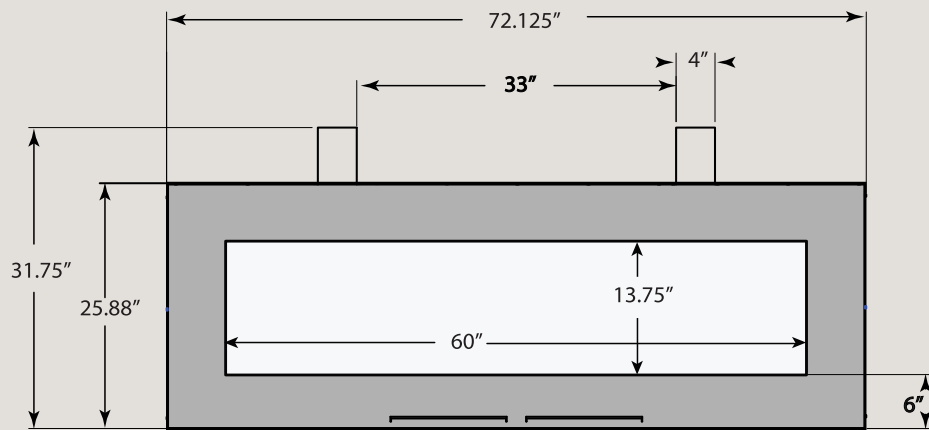

Right side view

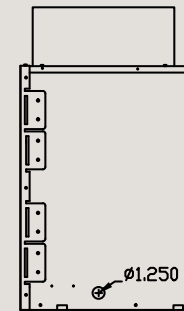

STANDARD FEATURES

- Can be framed in wooden structure and finished with non-combustible materials
- Ceramic glass wind baffle.
- Clear burner and tray glass media.
- High grade 304 stainless steel construction.
- Dynamic flame reflection from ember bed and brushed stainless steel interior.
- Electronic ignition system with battery back up.
- On/Off remote control with timer or wall switch.

AVAILABLE OPTIONS

- Various tray and burner glass media.
- Stainless steel safety screen.
- L.E.D. Light kit with custom media tray.



INPUT RATES

SS-60 (NG or LP): 75,000 Btu/h



SS-48

A fireplace to enhance any outdoor living area



FEATURES

- * 48" wide viewing area with brushed stainless steel interior and 6" border
- * High-grade 304 brushed stainless steel construction to ensure lasting quality
- * Ceramic glass wind baffle
- * On/Off remote control with timer
- * Electronic ignition system with battery back up



Top view

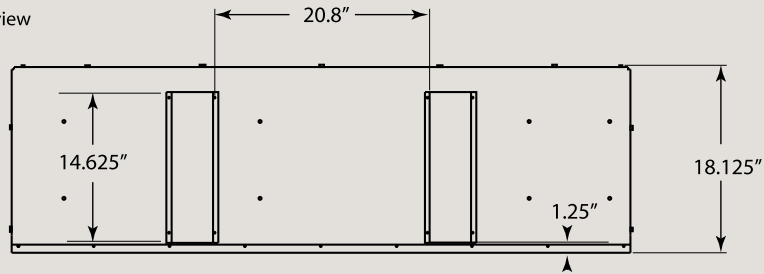

Front view

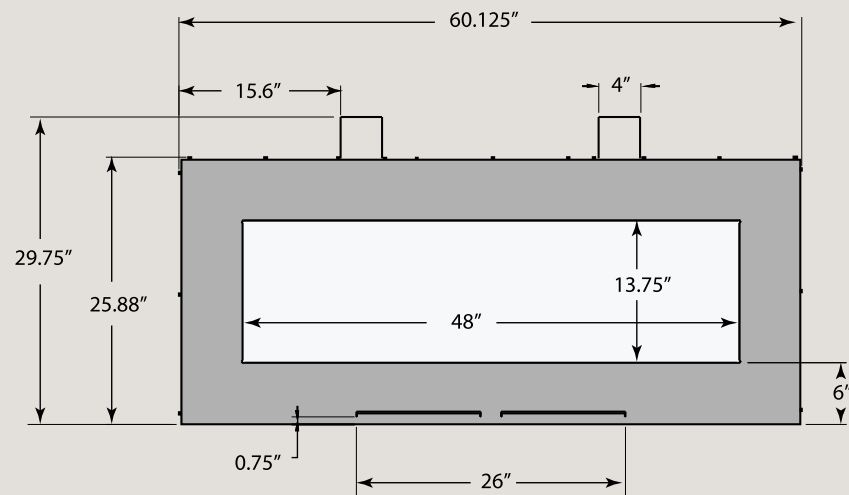

Right side view

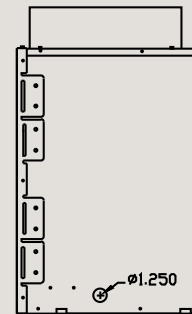

STANDARD FEATURES

- Can be framed in wooden structure and finished with non-combustible materials
- Ceramic glass wind baffle.
- Clear burner and tray glass media.
- High grade 304 stainless steel construction.
- Dynamic flame reflection from ember bed and brushed stainless steel interior.
- Electronic ignition system with battery back up.
- On/Off remote control with timer or wall switch.

AVAILABLE OPTIONS

- Various tray and burner glass media.
- Stainless steel safety screen.
- L.E.D. Light kit with custom media tray.



INPUT RATES

SS-48: 60,000 Btu/h (NG), 56,000 Btu/h (LP)



SS-36

Simple contemporary
design, unlimited
possibilities



FEATURES

- * 36" wide viewing area with brushed stainless steel interior and 6" border
- * High-grade 304 brushed stainless steel construction to ensure lasting quality
- * Ceramic glass wind baffle
- * On/Off remote control with timer
- * Electronic ignition system with battery back up



Top view

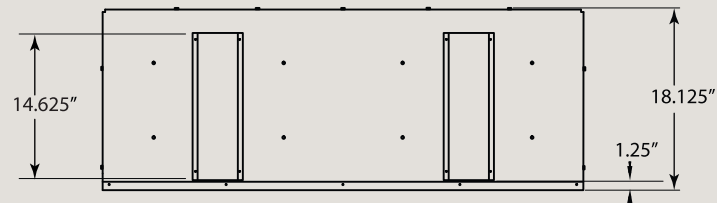

Front view

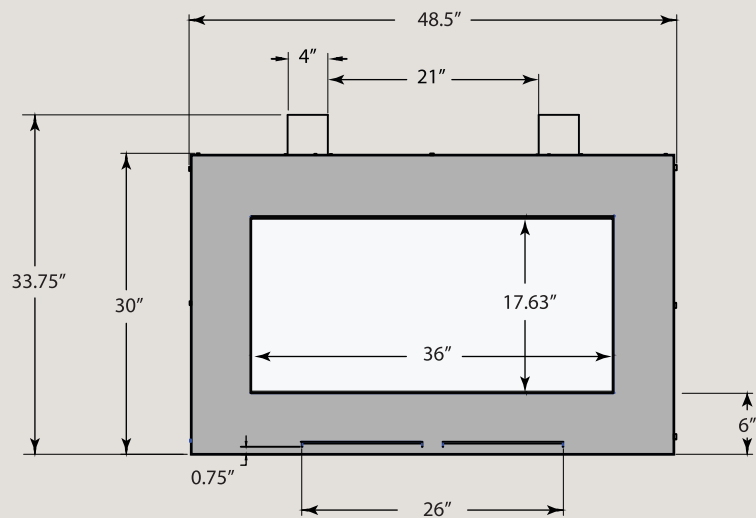

Right side view

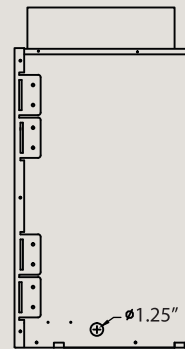

STANDARD FEATURES

- Can be framed in wooden structure and finished with non-combustible materials
- Ceramic glass wind baffle.
- Clear burner and tray glass media.
- High grade 304 stainless steel construction.
- Dynamic flame reflection from ember bed and brushed stainless steel interior.
- Electronic ignition system with battery back up.
- On/Off remote control with timer or wall switch.

AVAILABLE OPTIONS

- Various tray and burner glass media.
- Stainless steel safety screen.
- L.E.D. Light kit with custom media tray.



INPUT RATES

SS-36: 40,000 Btu/h (NG), 38,000 Btu/h (LP)

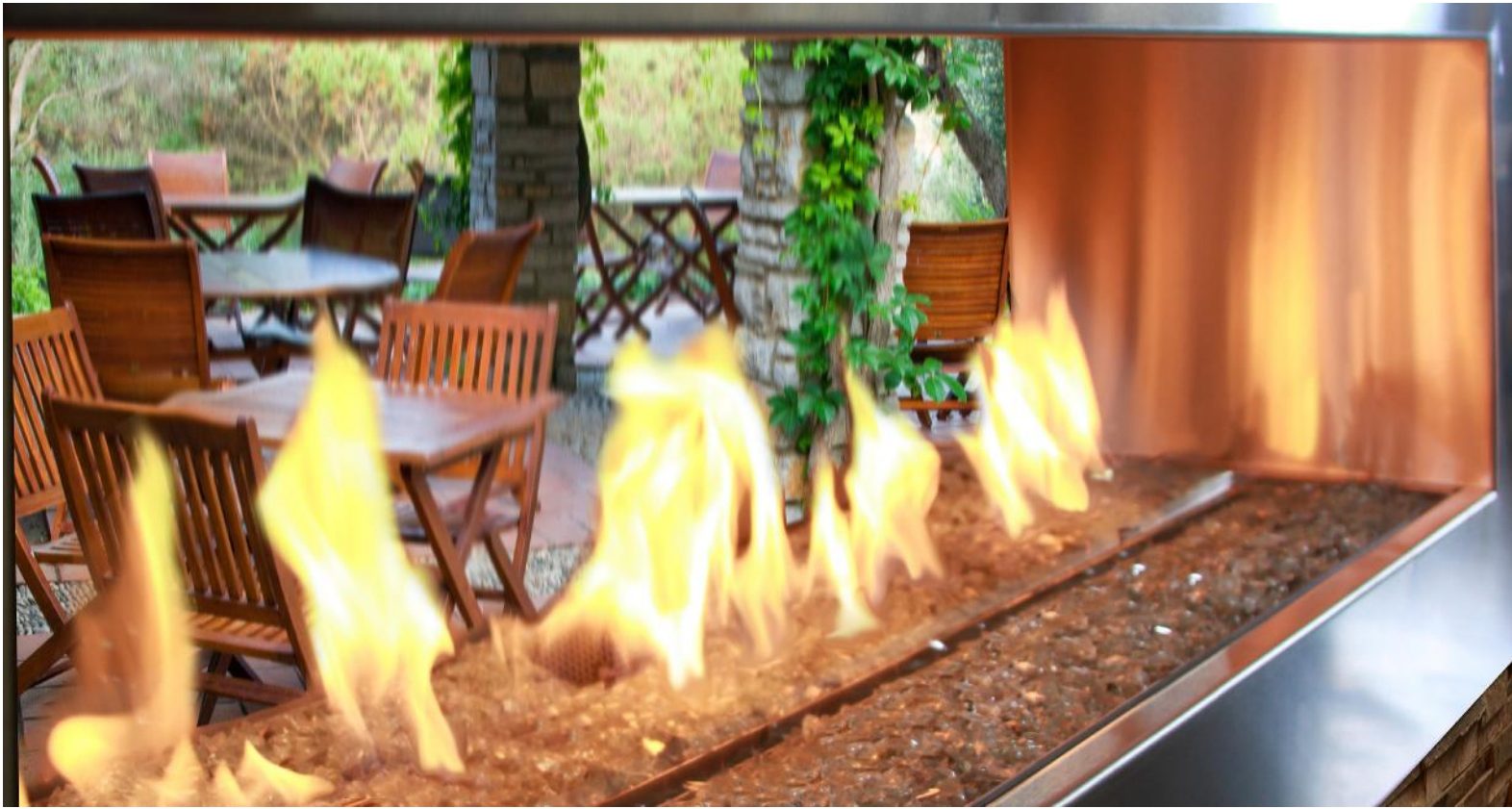

SS-72-ST, SS-60-ST
SS-48-ST, SS-36-ST
Creating a flow between
outdoor areas with warm
ambiance



FEATURES

- * See-thru design with 36", 48", 60", or 72" wide viewable opening and 6" border
- * Heavy gauge 304 brushed stainless steel construction
- * Electronic ignition system with battery back up
- * On/Off remote control with timer



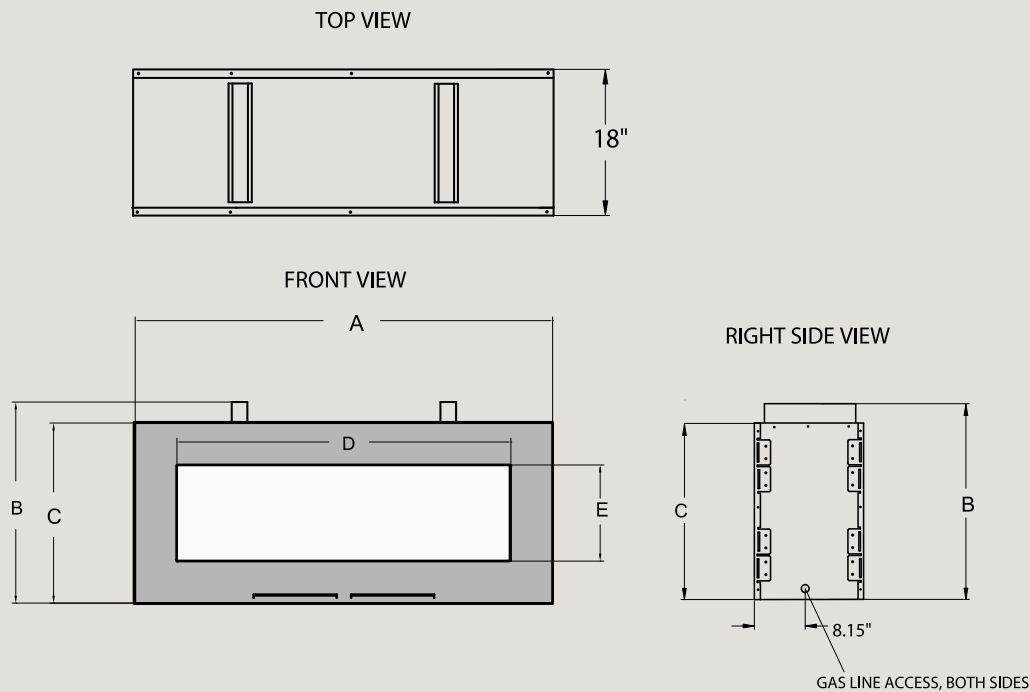

	SS-36-ST	SS-48-ST	SS-60-ST	SS-72-ST
A	48"	60"	72"	84"
B	33.75"	29.75"	31.75"	31.75"
C	29.75"	25.75"	25.75"	25.75"
D	36"	48"	60"	72"
E	17.31"	13.75"	13.75"	13.75"



STANDARD FEATURES

- Can be framed in wooden structure and finished with non-combustible materials
- Clear burner and tray glass media.
- High grade 304 stainless steel construction.
- Dynamic flame reflection from ember bed and brushed stainless steel interior.
- Electronic ignition system with battery back up.
- On/Off remote control with timer or wall switch.

AVAILABLE OPTIONS

- Various tray and burner glass media.
- Stainless steel safety screens.
- L.E.D. Light kit with custom media tray.



INPUT RATES

SS-72-ST: 90,000 Btu/h (NG) / 90,000 Btu/h (LP)
 SS-60-ST: 75,000 Btu/h (NG) / 75,000 Btu/h (LP)
 SS-48-ST: 60,000 Btu/h (NG) / 56,000 Btu/h (LP)
 SS-36-ST: 40,000 Btu/h (NG) / 38,000 Btu/h (LP)



SS-PIER (3-sided)

Creating a flow between
outdoor areas with warm
ambiance



FEATURES

- * See-thru design with 36", 48", or 60" wide viewable openings
- * Heavy gauge 304 brushed stainless steel construction
- * Electronic ignition system with battery back up
- * On/Off remote control with timer



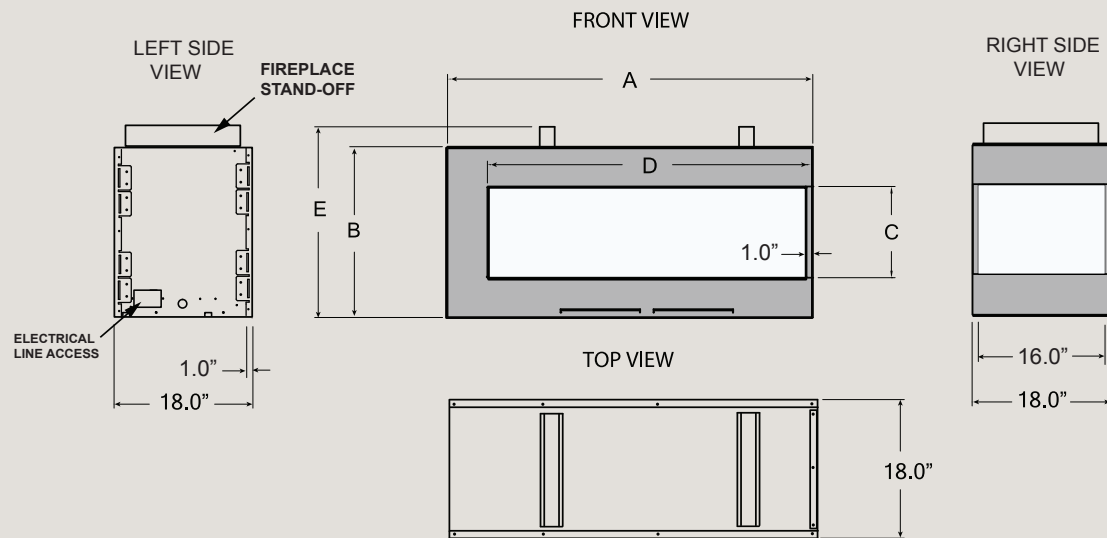

STANDARD FEATURES

- Can be framed in wooden structure and finished with non-combustible materials
- Clear burner and tray glass media.
- High grade 304 stainless steel construction.
- Dynamic flame reflection from ember bed and brushed stainless steel interior.
- Electronic ignition system with battery back up.
- On/Off remote control with timer or wall switch.

AVAILABLE OPTIONS

- Various tray and burner glass media.
- Stainless steel safety screens.
- L.E.D. Light kit with custom media tray.



	SS-36(N,P)-PIER	SS-48(N,P)-PIER	SS-60(N,P)-PIER
A	42"	54"	66"
B	29.75"	25.75"	25.75"
C	17"	13.5"	13.5"
D	36"	48"	60"
E	33.75"	29.75"	29.75"

INPUT RATES

SS-60-PIER: 75,000 Btu/h (NG) / 75,000 Btu/h (LP)
 SS-48-PIER: 60,000 Btu/h (NG) / 56,000 Btu/h (LP)
 SS-36-PIER: 40,000 Btu/h (NG) / 38,000 Btu/h (LP)



SS-BAY (3-sided)

Creating a flow between
outdoor areas with warm
ambiance

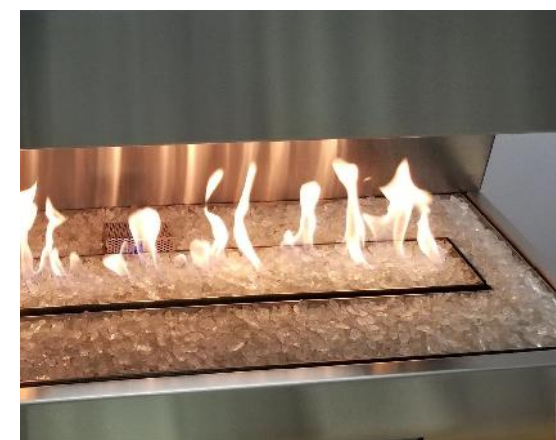

FEATURES

- * See-thru design with 36", 48", or 60" wide viewable openings
- * Heavy gauge 304 brushed stainless steel construction
- * Electronic ignition system with battery back up
- * On/Off remote control with timer



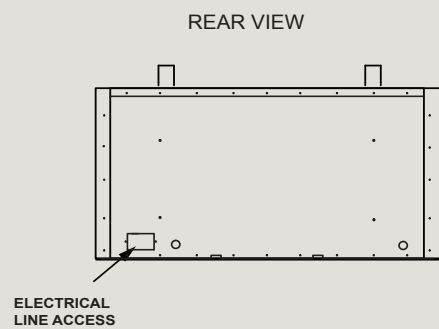
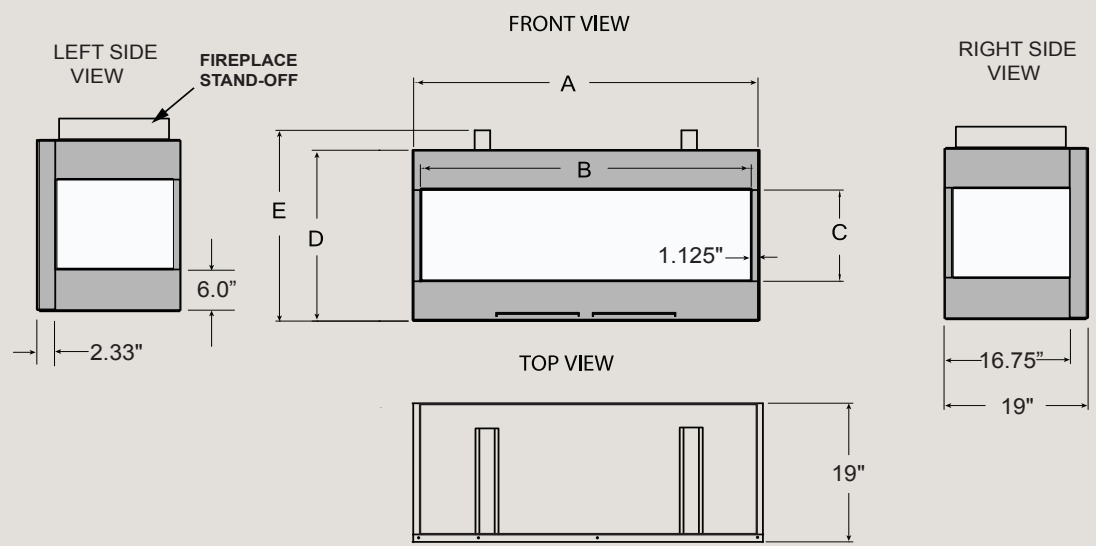

	SS-36(N,P)-BAY	SS-48(N,P)-BAY	SS-60(N,P)-BAY
A	36"	48"	60"
B	33.75"	45.75"	57.75"
C	17"	13.5"	13.5"
D	30"	26"	26"
E	33.75"	29.75"	29.75"



STANDARD FEATURES

- Can be framed in wooden structure and finished with non-combustible materials
- Clear burner and tray glass media.
- High grade 304 stainless steel construction.
- Dynamic flame reflection from ember bed and brushed stainless steel interior.
- Electronic ignition system with battery back up.
- On/Off remote control with timer or wall switch.

AVAILABLE OPTIONS

- Various tray and burner glass media.
- Stainless steel safety screens.
- L.E.D. Light kit with custom media tray.



INPUT RATES

SS-60-BAY: 75,000 Btu/h (NG) / 75,000 Btu/h (LP)
 SS-48-BAY: 60,000 Btu/h (NG) / 56,000 Btu/h (LP)
 SS-36-BAY: 40,000 Btu/h (NG) / 38,000 Btu/h (LP)



FIRE FEATURE ENCLOSURE

A true masterpiece
designed to impress



FEATURES

- * Simple lines, brushed steel finish, and impressive flame presentation
- * High-grade 304 stainless steel construction to withstand the outdoor elements
- * Available in 7 sizes with matching stainless steel rain covers
- * Various stone and fire glass options to complement any patio environment
- * On/Off remote controlled electronic ignition system for easy operation



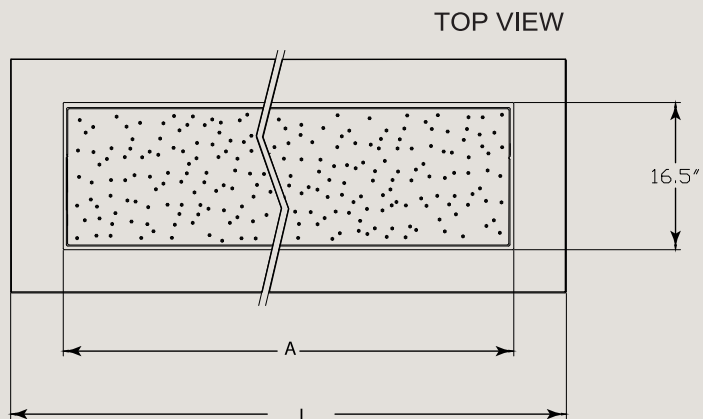

Model	L	A	B
FF24-ENC	36.125"	24.75"	29.75"
FF36-ENC	48.125"	36.75"	41.75"
FF48-ENC	60.125"	48.75"	53.75"
FF60-ENC	72.125"	60.75"	65.75"
FF72-ENC	84.125"	72.75"	77.75"
FF84-ENC	96.125"	84.75"	89.75"
FF96-ENC	108.125"	96.75"	101.75"

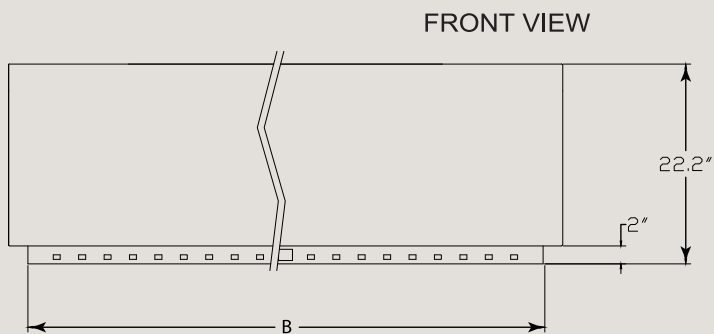

SIDE VIEW

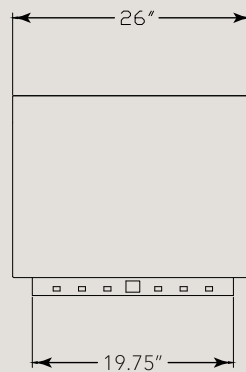

STANDARD FEATURES

- High grade 304 stainless steel construction.
- Clear burner and tray glass media.
- Dynamic flame reflection from ember bed and brushed stainless steel enclosure.
- Matching 304 stainless steel rain cover .
- Electronic ignition system with battery back up.
- On/Off remote control with timer .

AVAILABLE OPTIONS

- Various tray and burner glass media.

INPUT RATES

FF24-ENC :	41,000 Btu/h (NG)	33,500 Btu/h (LP)
FF36-ENC :	61,000 Btu/h (NG)	54,000 Btu/h (LP)
FF48-ENC :	82,000 Btu/h (NG)	72,000 Btu/h (LP)
FF60-ENC :	102,000 Btu/h (NG)	90,000 Btu/h (LP)
FF72-ENC :	116,000 Btu/h (NG)	110,000 Btu/h (LP)
FF84-ENC :	129,000 Btu/h (NG)	128,000 Btu/h (LP)
FF96-ENC :	142,000 Btu/h (NG)	146,500 Btu/h (LP)



SERPENTINE

A modern take on a traditional fire table



FEATURES

- * Distinctive "S" shaped burner, various fire glass color options to match any décor
- * High-grade 304 stainless steel construction to ensure lasting quality
- * On/Off remote control with timer and electronic ignition system with battery back up
- * Heavy duty vinyl cover to protect from outdoor elements



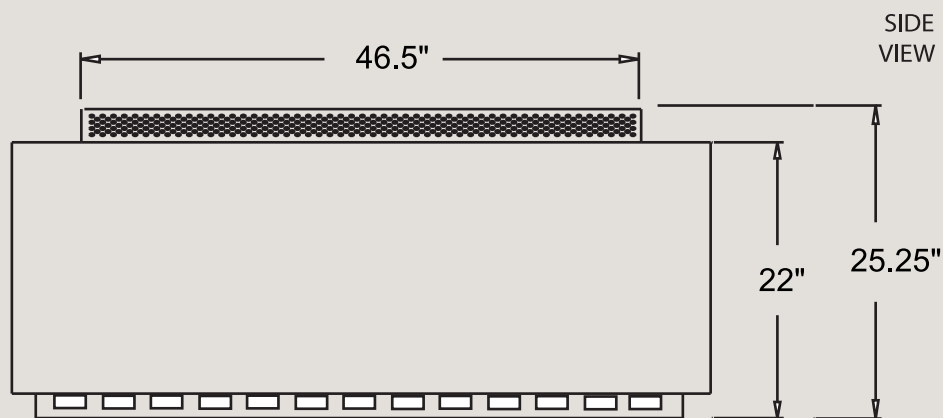
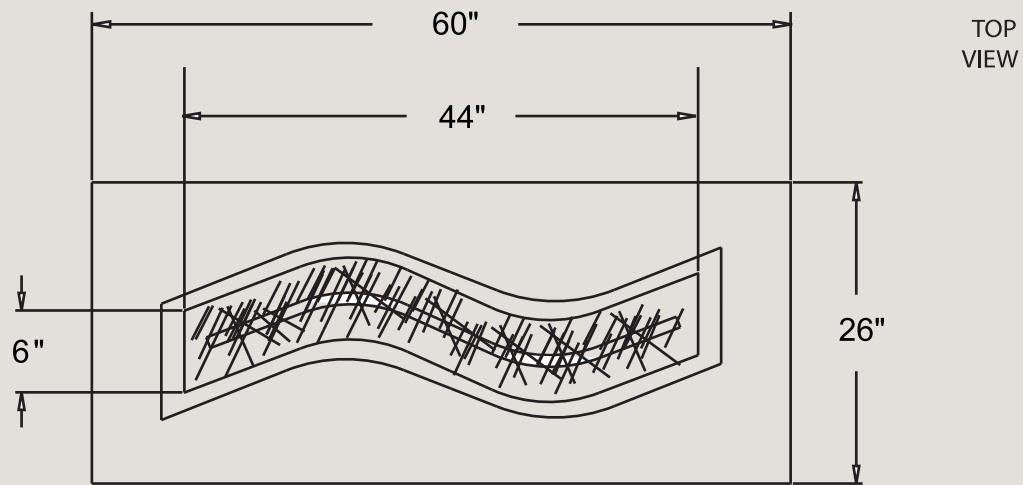

STANDARD FEATURES

- Brushed 304 stainless steel enclosure and wind guard.
- High grade 304 stainless steel burner construction.
- Clear glass burner media.
- Electronic ignition system with battery back-up.
- On/Off remote control or wall switch.
- Heavy duty vinyl cover to protect from outdoor elements.

AVAILABLE OPTIONS

- Various glass burner media.

INPUT RATE

SERPENTINE: 80,000 Btu/h (NG and LP)



FIRE TABLE

Easily add an eye catching element to your outdoor area



FEATURES

- * 21" square ember bed with various fire glass color options to match any décor
- * High-grade 304 stainless steel construction to ensure lasting quality
- * Safety pilot system with built-in On/Off gas valve
- * Heavy duty vinyl cover to protect from outdoor elements



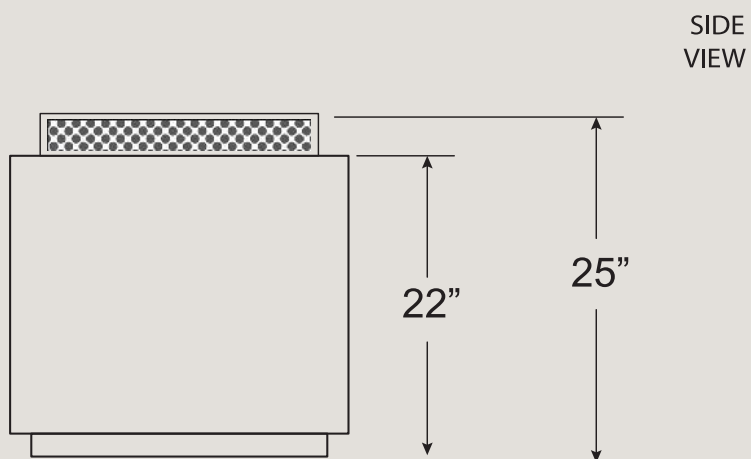
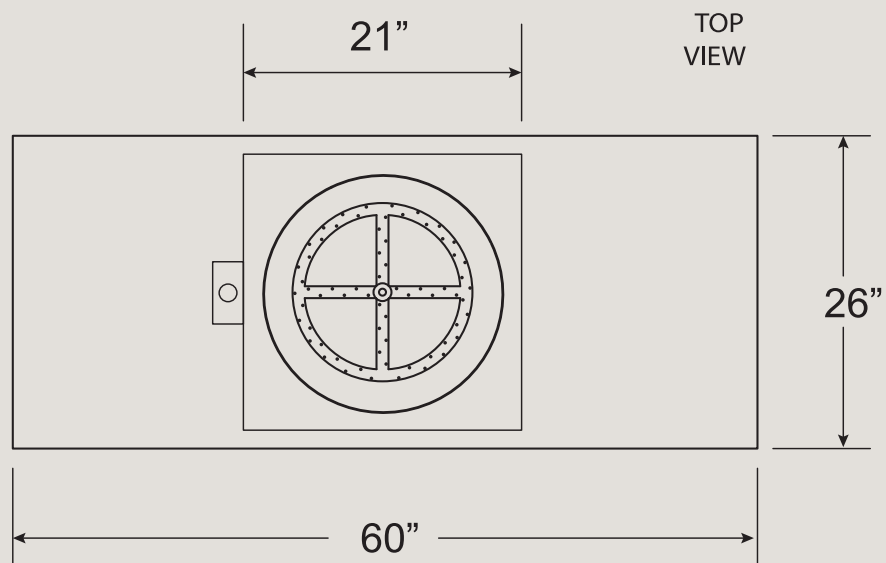

STANDARD FEATURES

- Brushed 304 stainless steel enclosure and square wind guard.
- High grade 304 stainless steel burner construction.
- Clear glass burner media.
- Safety pilot system (pilot must be lit manually with a BBQ lighter).
- On/Off safety gas valve.
- Heavy duty vinyl cover to protect from outdoor elements.

AVAILABLE OPTIONS

- Various glass and stone burner media.

INPUT RATES

FIRE TABLE-N: 60,000 Btu/h

FIRE TABLE-P: 54,000 Btu/h



SQUARE FIRE TABLE

Easily add an eye catching element to your outdoor area



FEATURES

- * 21" square ember bed with various fire glass color options to match any décor
- * High-grade 304 stainless steel construction to ensure lasting quality
- * Safety pilot system with built-in On/Off gas valve
- * Heavy duty cover to protect from outdoor elements



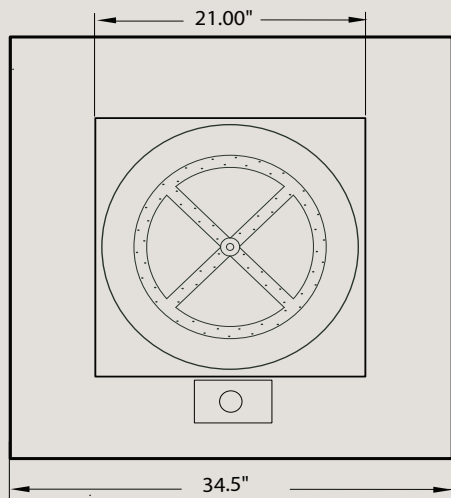
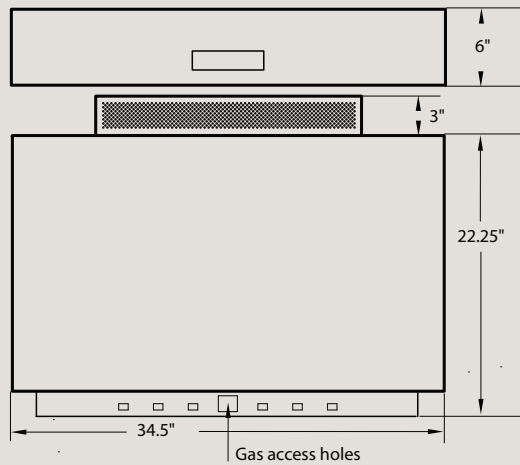

STANDARD FEATURES

- Brushed 304 stainless steel enclosure and square wind guard.
- High grade 304 stainless steel burner construction.
- Brushed 304 stainless cover to protect from outdoor elements.
- Safety pilot system (pilot must be lit manually with a BBQ lighter)
- On/Off safety gas valve.
- Clear glass burner media.

AVAILABLE OPTIONS

- Various glass and stone burner media.

INPUT RATES

FIRE TABLE-N: 60,000 Btu/h

FIRE TABLE-P: 54,000 Btu/h



SV-36, SV-48
SV-60, SV-72

An elegant transition
between interior and
exterior living spaces



FEATURES

- * See-thru design with 36", 48", 60", or 72" wide viewable opening and 6" border
- * Ceramic glass panel with safety screen on Indoor side; wind baffle on Outdoor side
- * Heavy gauge 304 brushed stainless steel construction
- * Electronic ignition system with battery back up
- * On/Off remote control with timer
- * Tested to ASTM standards: "Air Leakage" (E283), "Water Penetration" (E331), "Structural Performance" (E330)





STANDARD FEATURES

- Can be framed in wooden structure and finished with non-combustible materials
- Ceramic glass panel with safety screen on Indoor side
- Ceramic glass wind baffle on Outdoor side
- Clear burner and tray glass media.
- High grade 304 stainless steel construction.
- Dynamic flame reflection from ember bed and brushed stainless steel interior.
- Electronic ignition system with battery back up.
- On/Off remote control with timer or wall switch.

AVAILABLE OPTIONS

- Various tray and burner glass media.
- Stainless steel safety screens.
- L.E.D. Light kit with custom media tray.



INPUT RATES

SV-72: 90,000 Btu/h (NG) / 90,000 Btu/h (LP)
 SV-60: 75,000 Btu/h (NG) / 75,000 Btu/h (LP)
 SV-48: 60,000 Btu/h (NG) / 56,000 Btu/h (LP)
 SV-36: 40,000 Btu/h (NG) / 38,000 Btu/h (LP)

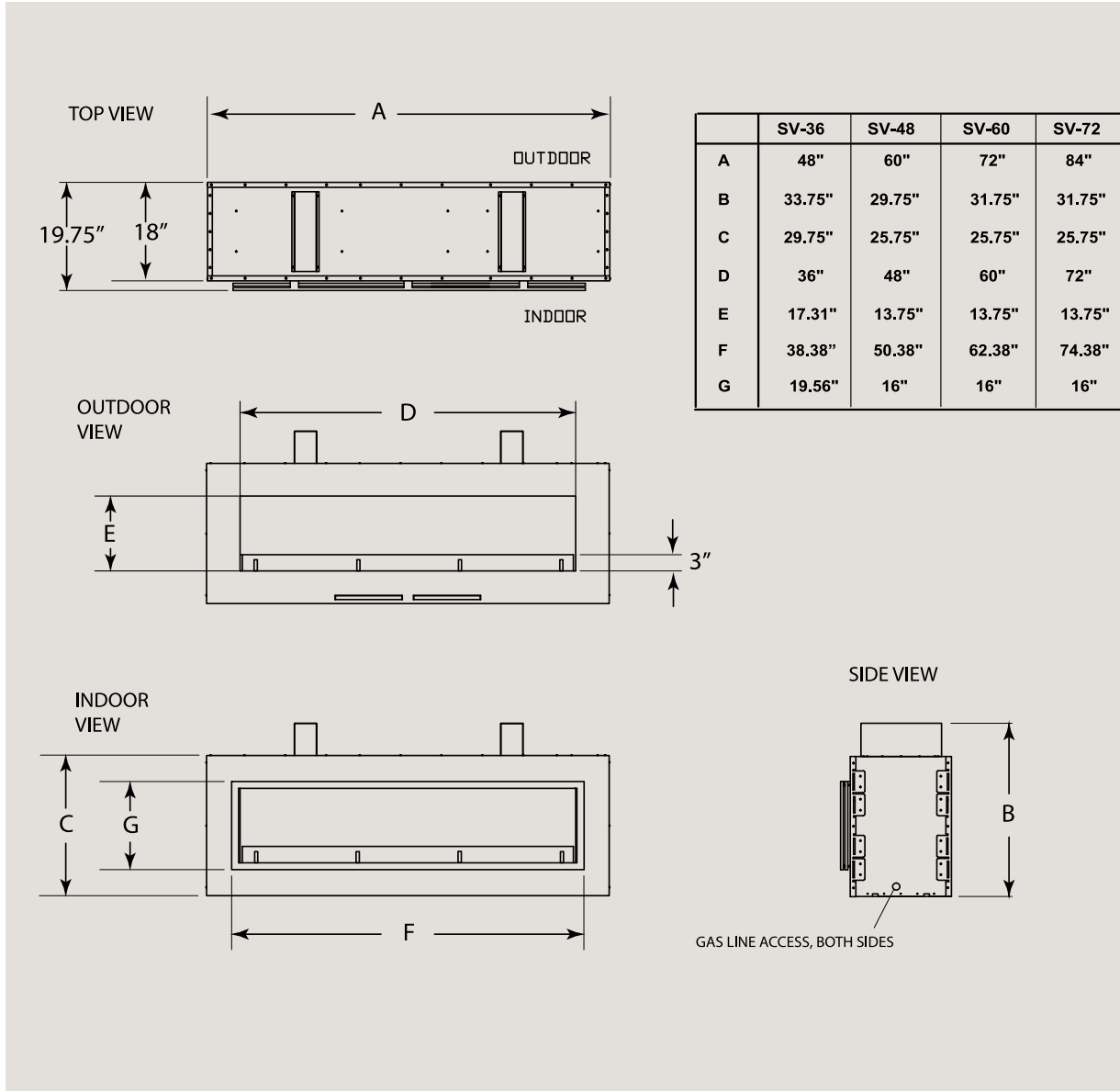



BONFIRE burner shown with stainless enclosure

BONFIRE
A centerpiece for outdoor entertaining



BONFIRE burner only shown

FEATURES

- * Electronic ignition system with On/Off wall switch for ease of operation
- * High grade 304 stainless steel burner construction to ensure lasting quality
- * Clear glass burner media and various fire glass top media color options
- * Optional one piece hand detailed log set for a campfire look
- * Optional brushed stainless steel enclosure and matching cover for a simple and complete installation



BURNER SPECIFICATIONS:

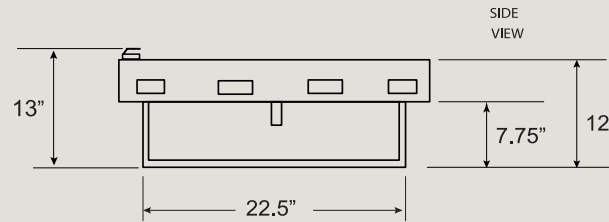

ENCLOSURE SPECIFICATIONS:

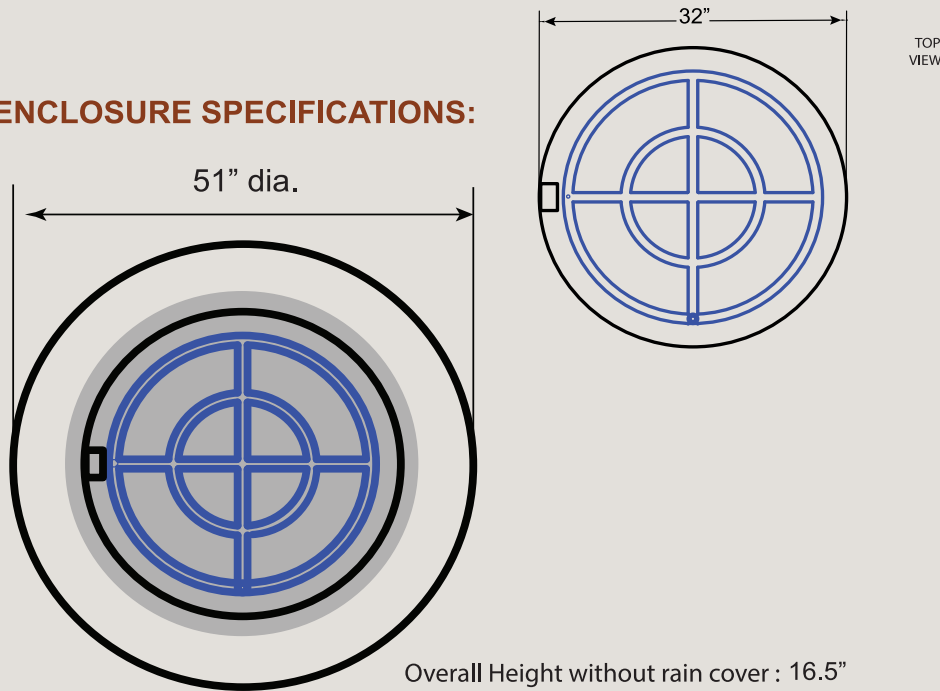

STANDARD FEATURES

- Electronic ignition system with On/Off switch
- Durable 304 stainless steel burner construction
- Stainless Steel 5/8" flex connector
- Clear glass burner media
- Limited lifetime warranty on burner
- Available for Natural Gas only
- Brushed 304 stainless steel enclosure (51" O.D. x 35" I.D. x 16.5" H)



- Brushed 304 stainless steel rain cover



AVAILABLE OPTIONS

- Various glass topping media
- One piece refractory log set



- 32" BONFIRE burner only for custom installations

INPUT RATE

Model BONFIRE (NG only): 192,000 Btu/h



CAMPFIRE

Gather around
with your friends



FEATURES

- * Electronic ignition system with On/Off wall switch for ease of operation
- * High grade 304 stainless steel construction to ensure lasting quality
- * Various fire glass and stone topping media options to match your design concept
- * Optional one piece hand detailed log set for a campfire look
- * Optional brushed stainless steel enclosure and matching cover for a simple and complete installation



BURNER SPECIFICATIONS:

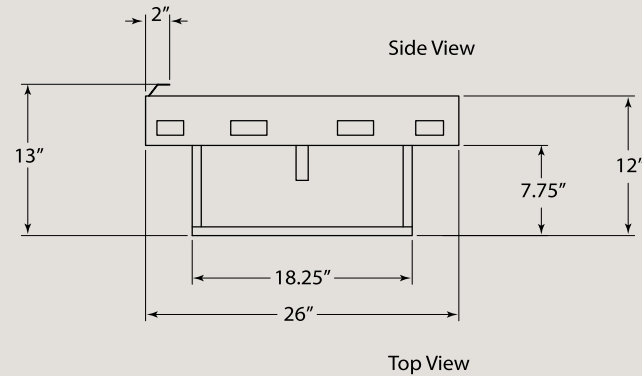

ENCLOSURE SPECIFICATIONS:

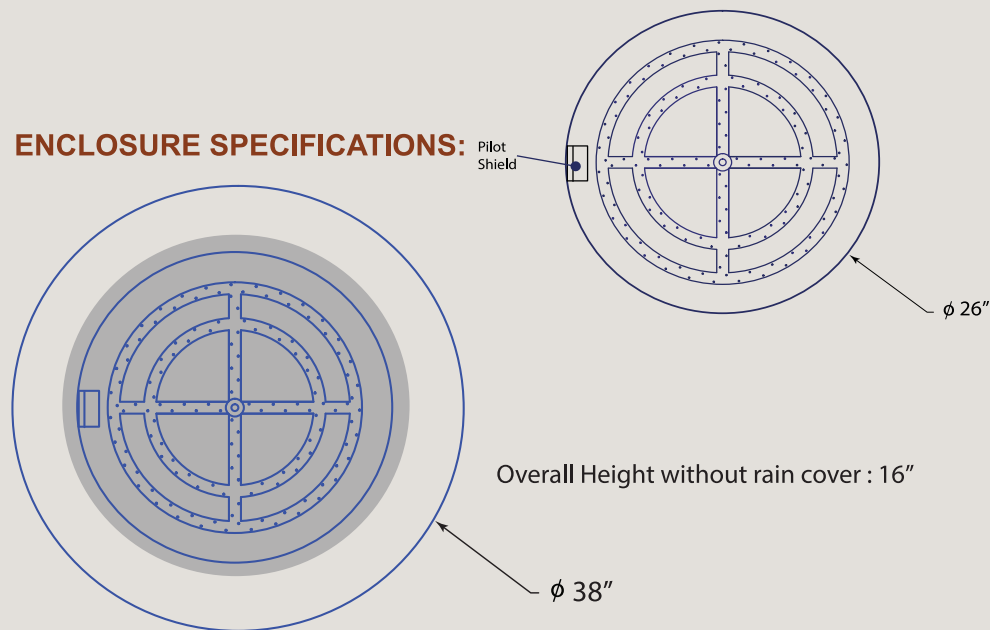

STANDARD FEATURES

- Electronic ignition system with On/Off switch
- Durable 304 stainless steel construction
- Stainless Steel 1/2" flex connector
- Clear glass burner media
- Limited lifetime warranty on burner
- Available for Natural Gas or LP
- Brushed 304 stainless steel enclosure
38" (D) x 16" (H)

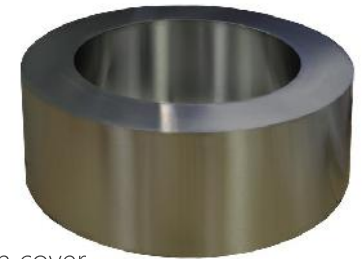

- Brushed 304 stainless steel rain cover



AVAILABLE OPTIONS

- Various glass topping media
- One piece refractory log set



- 26" CAMPFIRE burner only for custom installations

INPUT RATE

100,000 Btu/h (NG or LP)



Firepit Burner shown
in custom enclosure
(not provided)



FBB burner shown
with optional
stainless enclosure
and clear glass media



Clear
Glass



Dark Green
Glass



Black
Glass

FBB

Easily create your own
outdoor fire feature



FEATURES

- * Allows for a flexible design of your cozy seating area
- * High grade 304 stainless steel burner construction to ensure lasting quality
- * Various fire glass and stone topping media options to match your design concept
- * Optional one piece hand detailed log set for a campfire look
- * Optional brushed stainless steel enclosure and matching cover for a simple and complete installation

BURNER SPECIFICATIONS:

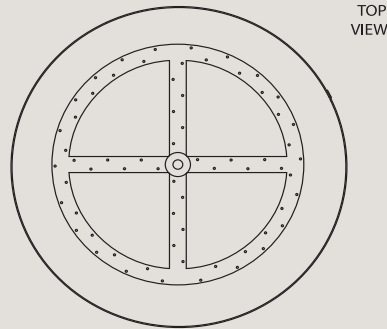
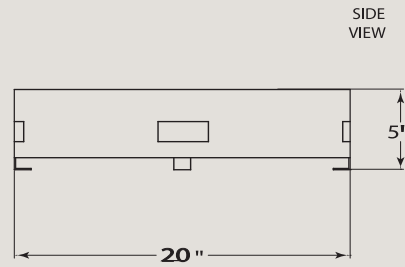

ENCLOSURE SPECIFICATIONS:

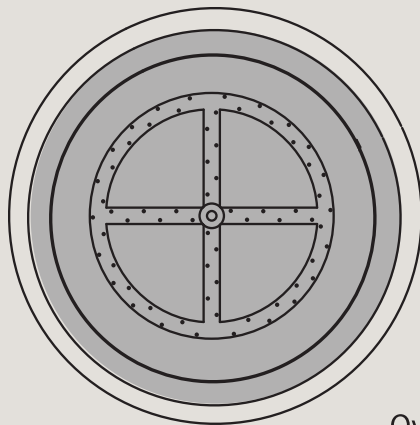

28" (O.D.)
26" (I.D.)

Overall height without rain cover: 16"

STANDARD FEATURES

- Manual burner lighting with a BBQ lighter
 - Manual turn off with main gas shut-off valve
 - Durable 304 stainless steel burner construction
 - Stainless Steel 1/2" flex connector
 - Clear glass burner media
 - Limited lifetime warranty on burner
 - Available for Natural Gas or LP
 - Brushed 304 stainless steel enclosure
- 28" (D) x 16" (H)



- Brushed 304 stainless steel rain cover

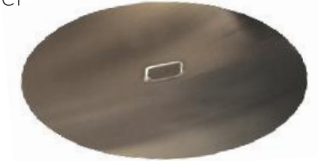

AVAILABLE OPTIONS

- Various glass topping media
- One piece refractory log set



- 20" FBB burner only for custom installations

INPUT RATES

FBB-N: 60,000 Btu/h
FBB-P: 54,000 Btu/h



Model FF-48 shown in custom enclosure

FIRE FEATURE
(BURNER)

Create Your
Own Outdoor
Living Paradise



FEATURES

- * Simple lines, brushed steel finish, and impressive flame presentation
- * High-grade 304 stainless steel construction to withstand the outdoor elements
- * Available in 7 sizes with matching stainless steel rain covers
- * Various stone and fire glass options to complement any patio environment
- * On/Off remote controlled electronic ignition system for easy operation
- * Can be used within a custom built non-combustible enclosure



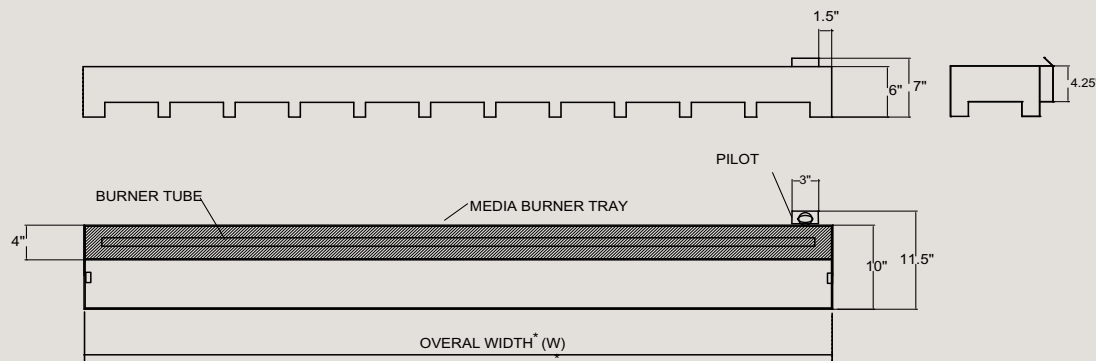

MODEL	OVERALL WIDTH (W)
FF-24	24.125"
FF-36	36.125"
FF-48	48.125"
FF-60	60.125"
FF-72	72.125"
FF-84	84.125"
FF-96	96.125"

TOP COVER DIMENSIONS

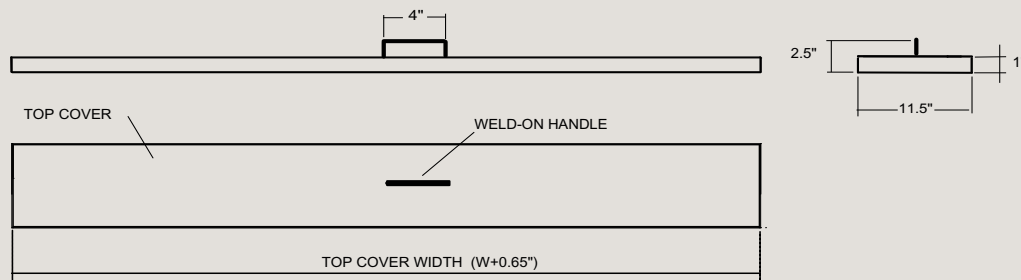

STANDARD FEATURES

- High grade 304 stainless steel construction.
- Clear burner and tray glass media.
- Dynamic flame reflection from ember bed
- Matching 304 stainless steel rain cover .
- Electronic ignition system with battery back up.
- On/Off remote control with timer .

AVAILABLE OPTIONS

- Various tray and burner glass media.
- Additional (rear) media tray.

INPUT RATES

FF24 :	41,000 Btu/h (NG)	33,500 Btu/h (LP)
FF36 :	61,000 Btu/h (NG)	54,000 Btu/h (LP)
FF48 :	82,000 Btu/h (NG)	72,000 Btu/h (LP)
FF60 :	102,000 Btu/h (NG)	90,000 Btu/h (LP)
FF72 :	116,000 Btu/h (NG)	110,000 Btu/h (LP)
FF84 :	129,000 Btu/h (NG)	128,000 Btu/h (LP)
FF96 :	142,000 Btu/h (NG)	146,500 Btu/h (LP)



GLO-18/GLO-24
Durable outdoor log
sets with endless
installation possibilities



FEATURES

- * Complete 304 stainless steel construction to withstand outdoor elements
- * Robust stainless steel grate made of ½" thick square bars for a substantial completed look
- * Extremely realistic hand detailed log set and various glass burner media
- * On/Off remote control for ease of operation



GLO-18 model



GLO-24 model



STANDARD FEATURES

- Extremely realistic and hand detailed cement log set.
- Various glass burner media.
- Brushed 304 stainless steel construction.
- Safety pilot system.
- ON/OFF remote control for ease of operation.

MINIMUM FIREBOX DIMENSIONS

(non-combustible structure):

GLO-18: 30" (front) x 23" (rear) x 30" (tall) x 16" (deep)

GLO-24: 36" (front) x 24" (rear) x 32" (tall) x 16" (deep)

INPUT RATES

GLO-18 (NG or LP): 45,000 Btu/h

GLO-24 (NG or LP): 60,000 Btu/h



QUALITY HEATING & LEISURE PRODUCTS

www.woodbridgedealer.com



Proudly made in North America!

Woodbridge Fireplace Inc.
1305 Meyerside Dr., Mississauga,
ONTARIO, CANADA L5T 1C9
Tel: 1-844-636-FIRE (3473)