

# Classic Collection

## Woodbridge Gas Fireplaces



LAGUNA

### LAGUNA SEE-THRU GAS FIREPLACE:

- \* Elegant transition between living areas.
- \* Substantial 48" wide see-thru viewing area.
- \* Standing pilot or electronic ignition control systems.
- \* Heavy duty construction, ceramic glass, and safety screens.
- \* Efficiency up to 75% , standard 140 C.F.M. thermostatic blower
- \* Fireplace faces can be covered for a minimalistic look (as shown).



# Classic Collection

## Woodbridge Gas Fireplaces



# LAGUNA

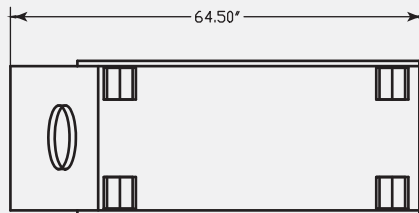
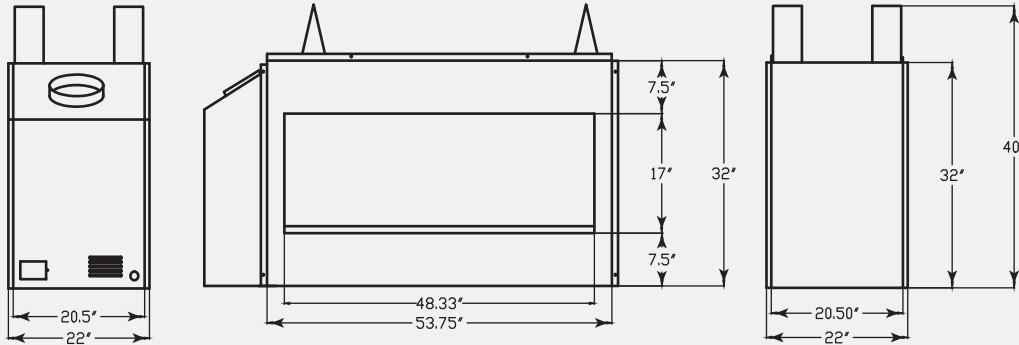

### Gas input rate:

Model LAGUNA-N-(E): Nat. Gas 26,000 - 37,500 Btu/h  
 Model LAGUNA-P-(E): Propane 27,000 - 37,000 Btu/h

Efficiency ..... up to 75%  
 EnerGuide FE Rating ..... 67.7% (NG)  
 70.9% (LP)

### Standard Features

- \* Realistic hand-detailed driftwood set and grey glass media.
- \* Durable ceramic glass and safety screen.
- \* Faces can be covered with non-combustible material for a minimalistic look.
- \* Standing pilot system with battery powered ignition.
- \* 140 C.F.M. , variable speed, thermostatic circulating blower.
- \* ON/OFF remote control with built-in timer.
- \* Limited Lifetime Warranty.

### Available Options:

- \* Electronic ignition with battery back-up.
- \* Remote control with built-in thermostat and flame height control.
- \* Stainless steel or metallic brown face.



**SHOWROOM OPEN TO THE PUBLIC:**  
 1305 Meyerside Dr,  
 Mississauga, ON L5T 1C9  
 Phone: (905) 564-3001  
[www.woodbridgefp.com](http://www.woodbridgefp.com)

