

Woodbridge Fireplace Inc.



DIRECT VENT GAS INSERT
MODEL DVI 751 (N,P)-E
with electronic ignition system



INSTALLATION AND OPERATING INSTRUCTIONS

WARNING: FIRE OR EXPLOSION HAZARD

Failure to follow safety warnings exactly could result in serious injury, death, or property damage.

- Do not store or use gasoline or other flammable vapors and liquids in the vicinity of this or any other appliance.
- **WHAT TO DO IF YOU SMELL GAS**
 - Do not try to light any appliance.
 - Do not touch any electrical switch; do not use any phone in your building.
 - Leave the building immediately.
 - Immediately call your gas supplier from a neighbor's phone. Follow the gas supplier's instructions.
 - If you cannot reach your gas supplier, call the fire department.
- Installation and service must be performed by a qualified installer, service agency or the gas supplier.

WARNING: Improper installation, adjustment, alteration, services or maintenance can cause injury or property damage. Refer to this manual. For assistance or additional information consult a qualified installer, service agency or the gas supplier.

This appliance may be installed in an aftermarket, permanently located, manufactured home (USA only) or mobile home where not prohibited by local codes.

This appliance is only for use with the type of gas indicated on the rating plate. This appliance is not convertible for use with other gases, unless a certified kit is used.

DANGER



HOT GLASS WILL CAUSE BURNS.
DO NOT TOUCH GLASS UNTIL COOLED.
NEVER ALLOW CHILDREN TO TOUCH GLASS.

A barrier designed to reduce the risk of burns from the hot viewing glass is provided with this appliance and shall be installed for the protection of children and other at-risk individuals.

DUE TO HIGH TEMPERATURES, THE APPLIANCE SHOULD BE LOCATED OUT OF TRAFFIC AND AWAY FROM FURNITURE AND DRAPERIES.

CHILDREN AND ADULTS SHOULD BE ALERTED TO THE HAZARDS OF HIGH SURFACE TEMPERATURE AND SHOULD STAY AWAY TO AVOID BURNS OR CLOTHING IGNITION.

YOUNG CHILDREN SHOULD BE SUPERVISED WHEN THEY ARE IN THE SAME ROOM AS THE APPLIANCE.

CLOTHING OR OTHER FLAMMABLE MATERIAL SHOULD NOT BE PLACED ON OR NEAR THE APPLIANCE.

KEEP THE ROOM AREA CLEAR AND FREE FROM COMBUSTIBLE MATERIALS, GASOLINE, AND OTHER FLAMMABLE VAPORS AND LIQUIDS.

INSTALLER: Leave this manual with the appliance.
CONSUMER: Retain this manual for future reference.

Version française de ce manuel est disponible à partir du site WEB : www.woodbridgefp.com

French version of this Owners Manual is available at www.woodbridgefp.com

CONTENTS

Important Safety Information	3	Glass Media and Stone Set Placement	18
Product Specification.....	5	Glass replacement	21
Code Approval	5	Installing facing	22
Pre-Installation Information		Operating Instructions	23
Installing Above 2000 Feet.....	6	What To Do If You Smell Gas.....	23
Orifice Sizes, Pressures and BTUs.....	6	Lighting Pilot for the First Time	23
Installation Planning	6	Lighting Pilot	24
Fireplace and Insert Dimensions	7	Lighting Burner.....	24
General Installation Information	8	To Turn Off Gas.....	24
Clearances	8	Flame Height Control, Thermostat.....	25
Installation.....	9	Cleaning Maintenance.....	27
Insert Placement.....	9	Venting System	27
Zero-Clearance (Metal) Fireplace		Cleaning Glass.....	27
Requirements.....	10	Pilot and Burner Flames	27
Vent Installation	11	Firebox Cleaning.....	27
Installation Precautions	11	Maintenance.....	28
Vent Requirements	12	Maintaining Your Heater's Appearance.....	28
Altitude Considerations	12	Yearly Service Procedure.....	28
Manifold Removal.....	13	Blower.....	29
Manifold Installation	13	Replacement Parts	30
Insert Installation		Troubleshooting	35
Check Gas Type.....	14	Warranty	Back Cover
Installing Gas Piping to Insert/Burner System			
Location	14		
Checking Gas Pressure	16		
Electrical Installation	17		
Electrical Wiring	17		
Blower Assembly Diagrams	17		

INSTALLER

Please leave these instructions with the owner.

OWNER

Please retain these instructions for future reference.

WARNING

- **Read this owner's manual carefully and completely before trying to assemble, operate, or service this insert.**
- **Any change to this insert or its controls can be dangerous.**
- **Improper installation or use of this insert can cause serious injury or death from fire, burns, explosions, electrical shock and carbon monoxide poisoning.**

This insert is a vented product. This insert must be properly installed by a qualified service person. The glass door must be properly seated and sealed. If this unit is not properly installed by a qualified service person with glass door properly seated and sealed, combustion leakage can occur.

CARBON MONOXIDE POISONING: Early signs of carbon monoxide poisoning are similar to the flu with headaches, dizziness and/or nausea. If you have these signs, the insert may not have been installed properly. Get fresh air at once! Have the insert inspected and serviced by a qualified service person. Some people are more affected by carbon monoxide than others. These include pregnant women, people with heart or lung disease or anemia, those under the influence of alcohol, and those at high altitudes.

Propane/LP gas and natural gas are both odorless. An odor-making agent is added to each of these gases. The odor helps you detect a gas leak. However, the odor added to these gases can fade. Gas may be present even though no odor exists.

Make certain you read and understand all warnings. Keep this manual for reference. It is your guide to the safe and proper operation of this insert.

1. This appliance is only for use with the type of gas indicated on the rating plate. This appliance is not convertible for use with other gases unless a certified kit is used.
2. For propane/LP insert, do not place propane/LP supply tank(s) inside any structure. Locate propane/LP supply tank(s) outdoors. To prevent performance problems, do not use propane/LP fuel tank of less than 100 lbs. capacity.
3. If you smell gas
 - shut off gas supply.
 - do not try to light any appliance.
 - do not touch any electrical switch; do not use any phone in your building .
 - immediately call your gas supplier from a neighbor's phone. Follow the gas supplier's instructions.
4. Never install the appliance
 - in a recreational vehicle
 - where curtains, furniture, clothing, or other flammable objects are less than 36" from the front, top, or sides of the insert
 - in high traffic areas
 - in windy or drafty areas
5. This insert reaches high temperatures. Keep children and adults away from hot surfaces to avoid burns or clothing ignition. Insert will remain hot for a time after shutdown. Allow surfaces to cool before touching.
6. Carefully supervise young children when they are in the same room as the appliance.
7. Do not modify this insert under any circumstances. Any parts removed for servicing must be replaced prior to operating insert.
8. Turn insert off and let cool before servicing, installing, or repairing. Only a qualified service person should install, service, or repair the insert. Have burner system inspected annually by a qualified service person.
9. You must keep control compartments, burners, and circulating air passages clean. More frequent cleaning may be needed due to excessive lint and dust from carpeting, bedding material, pet hair, etc. Turn off the gas valve and pilot light before cleaning insert.
10. Have venting system inspected annually by a qualified service person. If needed, have venting system cleaned or repaired. See *Cleaning and Maintenance*, page 27.
11. Keep the area around your insert clear of combustible materials, gasoline, and other flammable vapor and liquids. Do not run insert where these are used or stored. Do not place items such as clothing or other flammable material near the appliance.

Continued on page 4

12. Do not use this insert to cook food or burn paper or other objects.
13. Never place anything on top of insert.
14. Do not use any solid fuels (wood, coal, paper, cardboard, etc.) in this insert. Use only the gas type indicated on rating plate.
15. This appliance, when installed, must be electrically grounded in accordance with local codes or in the absence of local codes, with the *National Electrical Code*, *ANSI/NFPA 70*, or the *Canadian Electrical Code*, *CSA C22.1*.
16. Do not obstruct the flow of combustion and ventilation air in any way. Provide adequate clearances around air openings into the combustion chamber along with adequate accessibility clearance for servicing and proper operation. Trim panels or surrounds shall not seal ventilation openings in the fireplace.
17. Do not use insert if any part has been exposed to or under water. Immediately call a qualified service technician to inspect the appliance and to replace any part of the control system and/or any gas control that has been under water.
18. Do not operate the appliance if any log is broken.
19. **WARNING: Do not operate the appliance with glass door removed. Replacement of the glass should be done by a licensed or qualified service person.**
20. Cutting any sheet-metal parts of the fireplace, in which the gas insert is to be installed, is PROHIBITED.
21. A gas appliance must not be connected to a chimney flue serving a separate solid-fuel burning appliance.
22. If the factory-built fireplace has no gas access hole(s) provided, an access hole of 1.5 inch (37 mm) or less may be drilled through the lower sides or bottom of the firebox in a proper workmanship like manner. This access hole must be plugged with non-combustible insulation after the gas supply line has been installed.
23. The fireplace flue damper can be fully blocked open or removed for installation of the gas fireplace insert.
24. The fireplace and fireplace chimney must be clean and in good working order and constructed of non-combustible materials. The chimney cleanouts must fit properly.
25. Refractory glass doors, screen rails, screen mesh and log grates can be removed from the fireplace before installing the gas fireplace insert.
26. Children and adults should be alerted to the hazards of high surface temperature and should stay away to avoid burns or clothing ignition.
27. **WARNING: Handle glass door with care to avoid striking or scratching it on hard objects. CAUTION: Do not operate appliance with the glass front removed, cracked or broken.**
28. **Installation and repair should be done by a qualified service person. The appliance should be inspected before use and at least annually by a professional service person. More frequent cleaning may be required due to excessive lint from carpeting, bedding material, etc. It is imperative that control compartments, burners, and circulating air passageways of the appliance be kept clean.**
29. **Young children should be carefully supervised when they in the same room as the appliance. Toddlers, young children, and others may be susceptible to accidental contact burns. A physical barrier is recommended if there are at risk individuals in the house. To restrict access to a fireplace or stove, install an adjustable safety gate to keep toddlers, young children, and other at risk individuals out of the room and away from hot surfaces.**

SAFETY SCREEN INFORMATION:

WARNING: A barrier (safety screen) designed to reduce the risk of burns from the hot viewing glass is provided with this appliance and shall be installed for the protection of children and other at-risk individuals.

IMPORTANT: Safety Screen must be in place when the fireplace is in operation. If the barrier becomes damaged, the barrier shall be replaced with the manufacturer's barrier for this appliance. Any safety screen, guard, or barrier removed for servicing the appliance, must be replaced prior to operating the appliance.

PRODUCT SPECIFICATIONS

- This appliance has been certified for use with either natural or propane gas. See appropriate data plates.
- This appliance is not for use with solid fuels.
- The appliance is approved for bedroom or bedsitting room installations.
- The installation must conform with local codes or, in the absence of local codes, with the *National Fuel Gas Code, ANSI Z223.1/NFPA 54*, or the *National Gas and Propane Installation Code, CSA B149.1*.
- This appliance is mobile home approved.
- The appliance must be properly connected to a venting system.

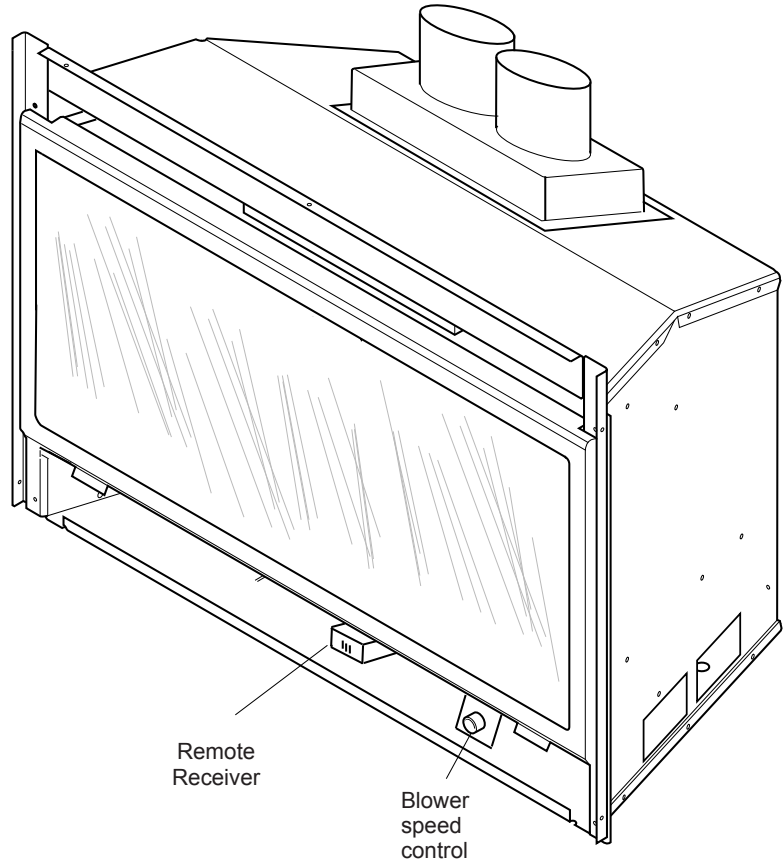

Figure 1 - DVI 751-E Insert

CODE APPROVAL

Direct Vent type appliances draw all combustion air from outside of the dwelling through the vent pipe.

These appliances have been listed by OMNI and found to comply with the established standards for DIRECT VENT GAS FIREPLACE HEATERS in the USA and Canada as follows:

LISTED VENTED GAS FIREPLACE HEATER

TESTED TO: ANSI Z21.88-2014/CSA 2.33-2014, CGA 2.17-M91 (R2009), CSA P.4.1-15 STANDARDS

This appliance may be installed in an aftermarket, permanently located, manufactured home (USA only) or mobile home, where not prohibited by local codes.

**This appliance is only for use with the type of gas indicated on the rating plate.
This appliance is not convertible for use with other gases, unless a certified kit is used.**

PRE-INSTALLATION INFORMATION

INSTALLING ABOVE 2000 FEET

- In the USA, the appliance must be derated 4% for every 1,000 ft above 2,000 ft elevations.
- In Canada, these appliances are certified for altitudes of 0 – 4500 ft, and must be de-rated an additional 4% for every 1,000 ft. above 4,500 ft. elevations.

ORIFICE SIZES, PRESSURES AND BTUs

NATURAL GAS

Manifold Press: (W.C.)	3.5"
Maximum Supply Pressure	10.5"
Minimum Supply Pressure	4.5"

PROPANE GAS

Manifold Press: (W.C.)	10"
Maximum Supply Pressure	13"
Minimum Supply Pressure	11"

Model Number	DVI751-E	
	NATURAL	PROPANE
Max. Btu/hr Input	28,500	25,500
Min. Btu/hr Input	18,000	20,000
Orifice sizes	#38	#53

INSTALLATION PLANNING

Plan for the installation of your insert. This includes determining the size of fireplace in which unit is to be installed, length of venting to be used, and finishing details, and whether any optional accessories (i.e. wall switch, or remote control) are desired. Consult your local building code agency to ensure compliance with local codes, including permits and inspections.

The installer must mechanically attach the marking supplied with the gas fireplace insert to the inside of the fireplace into which the gas fireplace insert is installed.

***NOTE: DVI 751-E model insert works with 7v DC electrical supply.
Optional blower must have 110V AC electricity.***

FIREPLACE AND INSERT DIMENSIONS

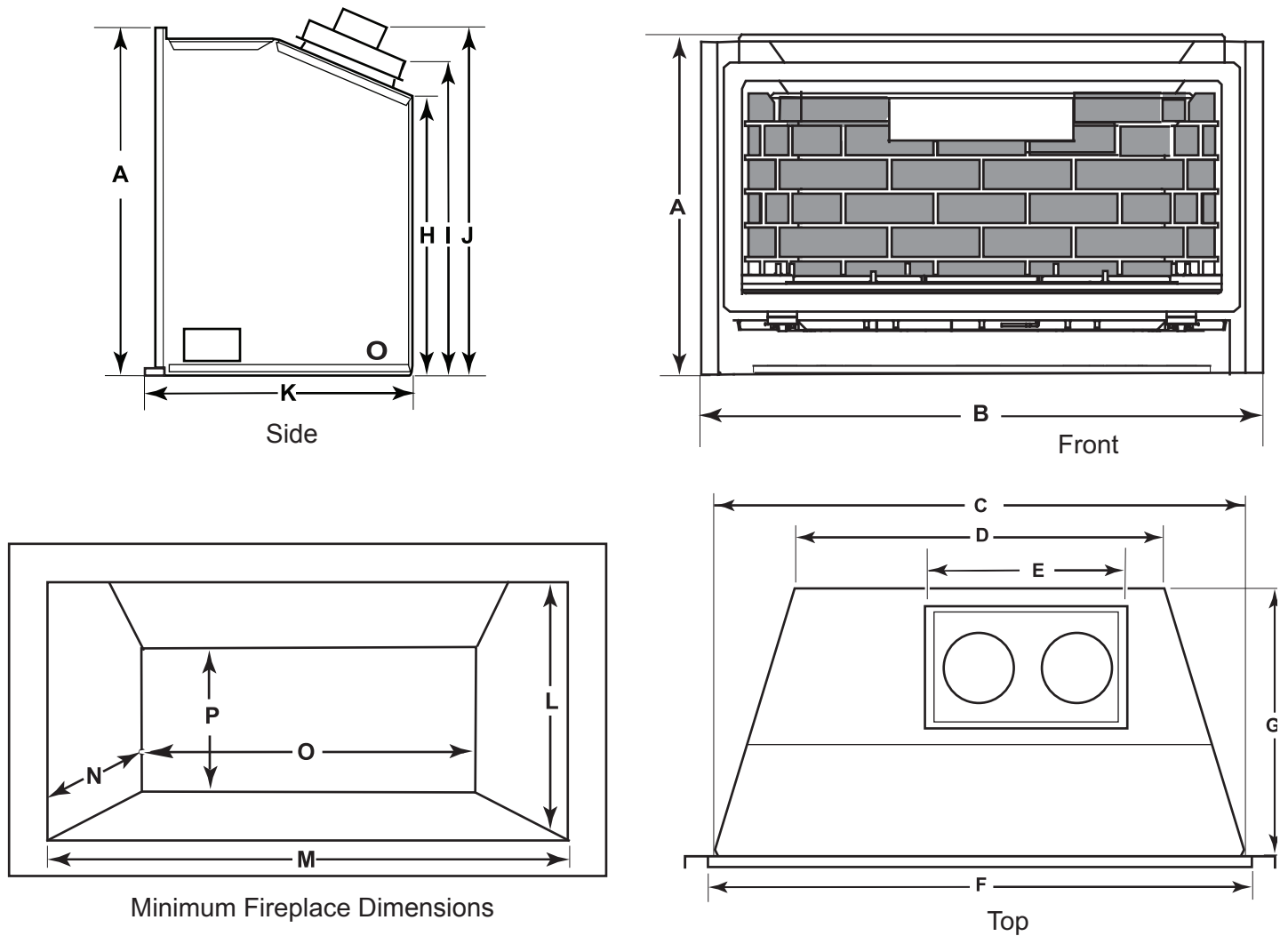

Figure 2 - Minimum Fireplace and Insert Dimensions

- L - Front height
- M - Front width
- N - Depth
- O - Rear width
- P - Rear height

DIMENSIONS								
DVI 751			DVI 751			FIREPLACE		
A	20.75"	527 mm	D	22.00"	559 mm	L	22.5"	565 mm
B	29.75"	756 mm	E	12.00"	305 mm	M	27.0"	686 mm
C	27.25"	692 mm	F	28.75"	730 mm	N	14.0"	356 mm
			G	13.50"	343 mm	O	24.0"	610 mm
			H	15.75"	400 mm	P	20.0"	508 mm
			I	19.25"	489 mm			
			J	21.25"	540 mm			
			K	14.25"	362 mm			

GENERAL INSTALLATION INFORMATION

The following factors should be taken into consideration:

- This insert should have sufficient access for its safe operation and maintenance.
- The flow of combustion and ventilation air must not be obstructed.
- Minimum clearances to combustibles, such as mantels, **must be maintained**.
- Never obstruct the front opening of the insert.
- Do **not** install in the vicinity where gasoline or other flammable liquids may be stored.
- These units can be installed in a bedroom. See National Fuel Gas Code ANSI Z233.1/NFPA 54 (current edition), the Uniform Mechanical Code (current edition), and Local Building Codes for specific installation requirements.

INSERT APPLICATIONS

IMPORTANT: Your direct vent insert is designed to be only vented vertically with a minimum height of 10 feet.

Before installing the gas fireplace insert, consider the functioning needs of the fireplace. Confirm the size of the fireplace cavity, the design of the chimney, and the availability of the gas supply and electricity for the insert fan.

MINIMUM FIREPLACE SIZE/CLEARANCES TO COMBUSTIBLES

IMPORTANT: Your direct vent insert was designed to be installed in an existing wood burning fireplace. The location and clearances are subject to local building codes and the requirements of the gas supplier and NFPA 211.

When the unit is installed into a woodburning fireplace, the minimum distance the mantel can be placed above the fireplace is governed by local building codes applicable to woodburning fireplaces. Consult local authorities having jurisdiction for these clearances. The underside of the mantel will become warm. Use only finishes which are heat resistant and do not discolor.

INSERT PLACEMENT

- Insert must be placed within a code-conforming masonry fireplace or a tested and listed zero-clearance (metal) fireplace. Repair any fireplace damage prior to installation.
- Because the insert uses a circulation blower, clean the fireplace, smoke shelf, and chimney before installing. Paint interior surface of the fireplace with latex paint to further eliminate dust.
- This heater may be placed in a bedroom. Please be aware of the large amount of heat this appliance produces when determining a location.

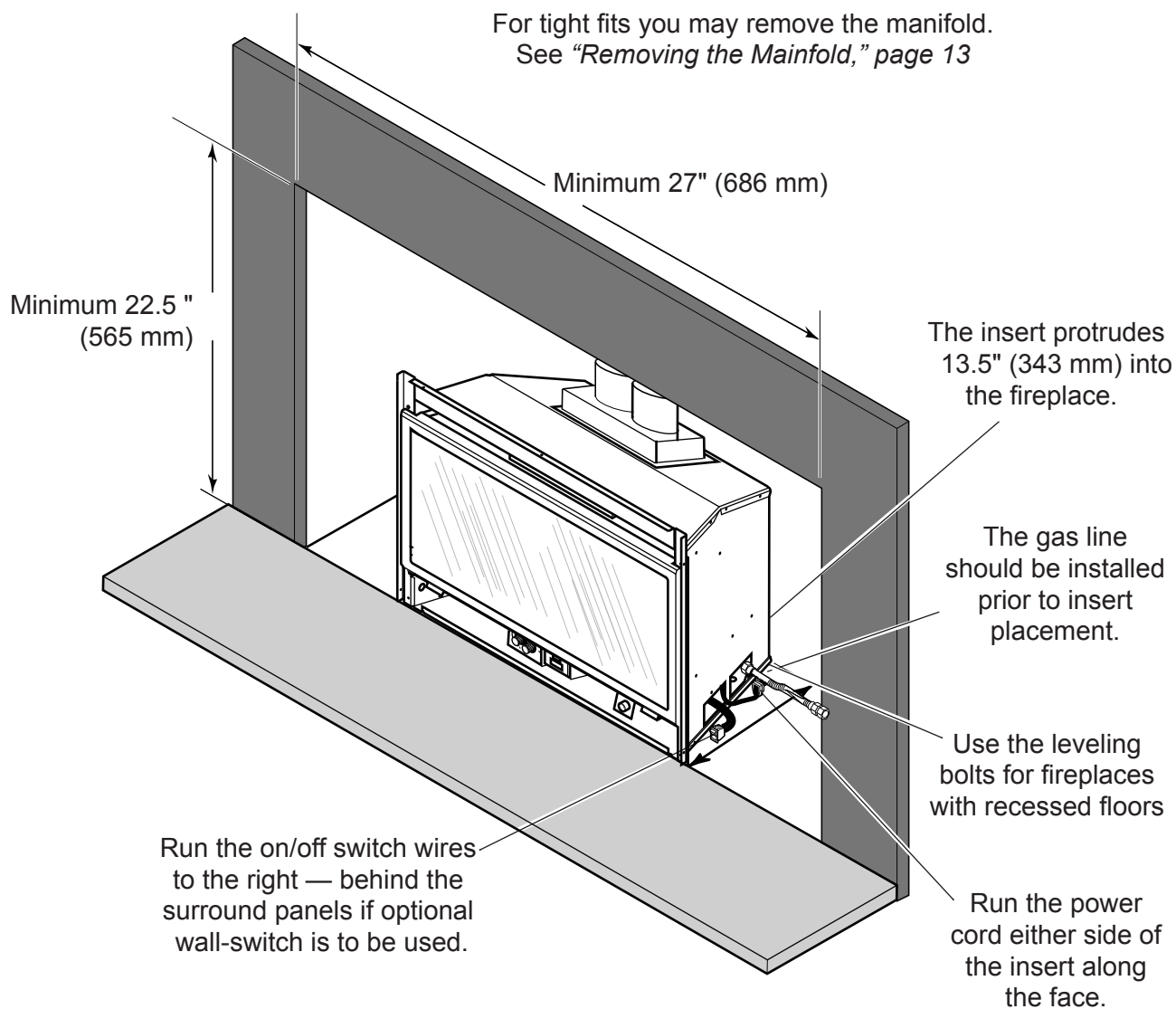
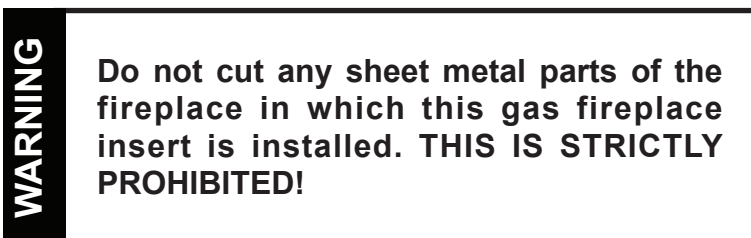

Figure 3 - Insert Placement

INSTALLATION

ZERO-CLEARANCE (METAL) FIREPLACE REQUIREMENTS

- The damper and grate must be removed.
- The smoke shelf internal baffles, screen, refractory, and metal or glass doors may be removed (if applicable).



- Do not remove or alter the insulation or any structured rigid frame members (metal sides, floor, door frame, face of the fireplace, etc.).

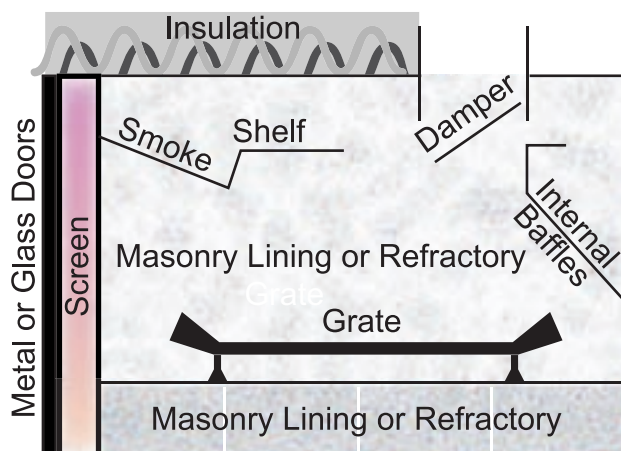

Figure 5 - Metal Fireplace Zero-Clearance Requirements

IMPORTANT: Please review the following carefully.

It is normal for inserts fabricated of steel to give off some expansion and/or contraction noises during the start up or cool down cycle. Similar noises are found with your furnace heat exchanger or car engine.

It is not unusual for your gas fireplace insert to give off some odor the first time it is burned. This is due to the curing of the paint and any undetected oil from the manufacturing process.

Please ensure that your room is well-ventilated. OPEN ALL WINDOWS DURING INITIAL BURN OFF/CURING PHASE.

Burn your insert for a least six (6) hours on “HIGH” the first time you use it. Place fan in the “OFF” position during this time.

WARNING

Read all instructions completely and thoroughly before attempting installation. Failure to do so could result in serious injury, property damage or loss of life. Operation of improperly installed and maintained venting systems could result in serious injury, property damage or loss of life.

NOTICE

Failure to follow these instructions will void the warranty.

INSTALLATION PRECAUTIONS

Consult local building codes before beginning the installation. The installer must make sure to select the proper vent system for installation. Before installing vent kit, the installer must read this insert manual and vent kit instructions.

Only a qualified installer/service person should install venting system. The installer must follow these safety rules:

- Wear gloves and safety glasses for protection.
- Use extreme caution when using ladders or when on rooftops.
- Be aware of electrical wiring locations in walls and ceilings.

The following actions will void the warranty on your venting system:

- Installation of any damaged venting component.
- Unauthorized modification of the venting system.
- Installation of any component part not manufactured or approved by Woodbridge Fireplace Inc..
- Installation other than permitted by these instructions.

INSPECTION OF VENT CONNECTION

WARNING

This insert must be vented to the outside. The venting system must **NEVER** be attached to a chimney serving a separate solid fuel burning appliance. Each gas appliance must use a separate vent system. Do not use common vent systems.

The vent connection can be inspected at the time of installation by removing the fireplace surround and outer face. See "INSTALLING SURROUND AND OUTER FACE" section of this manual.

VENT INSTALLATION

VENT REQUIREMENTS

WARNING

- Make sure the exhaust pipe on heater connects to exhaust portion of cap. Attach flex liners. See *Figure 6*.
- Do not crimp or rupture liner when bending it into chimney offsets.

- Vent must meet all vent manufacturer's requirements when installed.
- Make sure you have the following before installing unit:
 - 3" UL 1777 Listed gas liner for air inlet and exhaust (Q-ty: 2 pcs).
 - Vertical termination kit Duravent, Metal-Fab, or SelKirk.

ALTITUDE CONSIDERATIONS

This heater has been tested at altitudes ranging from sea level up to 4,500 feet (Canada), 0-2000 feet (USA). In this testing, heater with standard orifice burns correctly with just an air shutter adjustment. If you need to resize orifice for use at high altitude, contact your Woodbridge Fireplace dealer.

WARNING

Failure to adjust air shutter properly may lead to improper combustion which can create a safety hazard. Consult your dealer or installer if you suspect an improperly adjusted air shutter

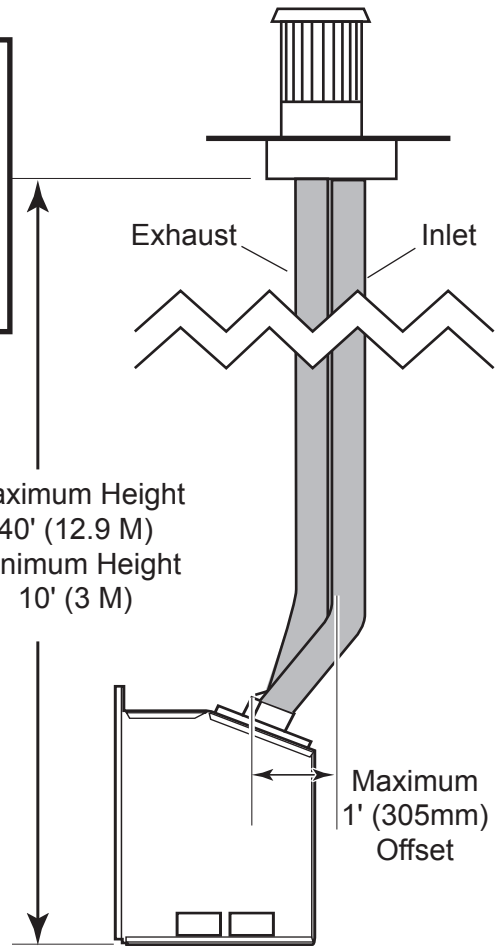

Figure 5 - Venting Unit

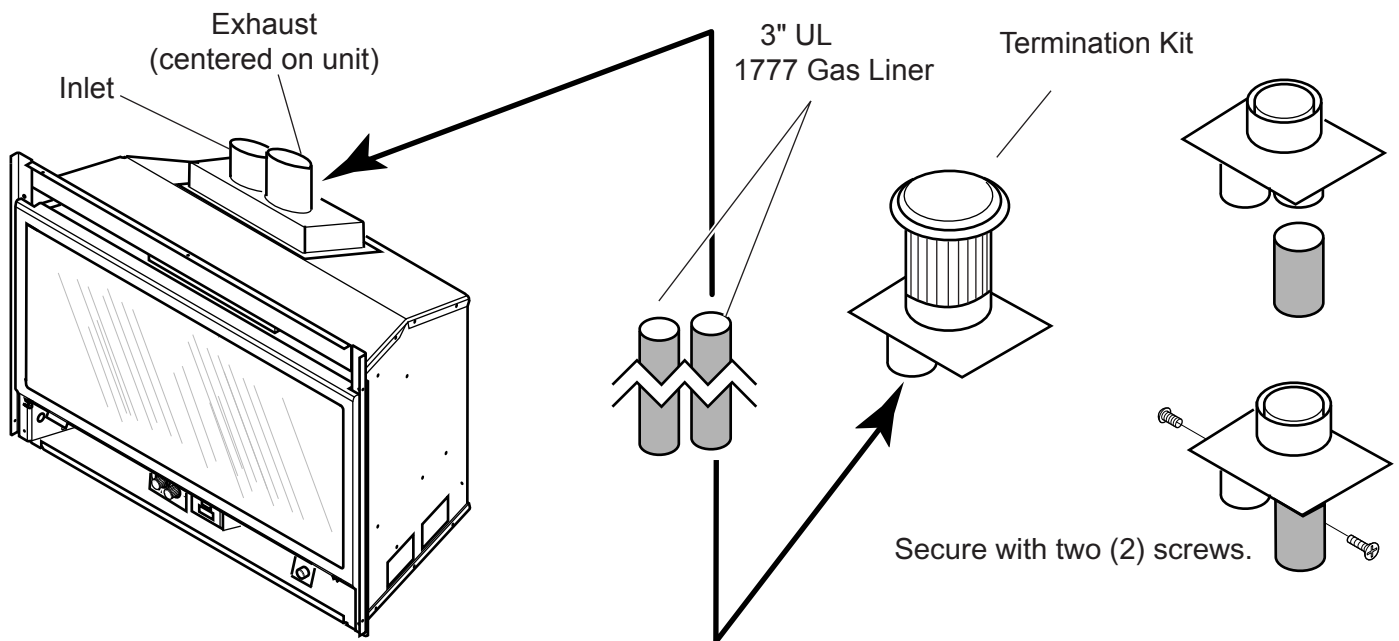

Figure 6 - Connecting Exhaust Pipe to Heater

MANIFOLD REMOVAL AND INSTALLATION

The manifold is shipped attached to insert. It may be removed to allow tight installation. Manifold may be loosened and rotated for desired pipe location.

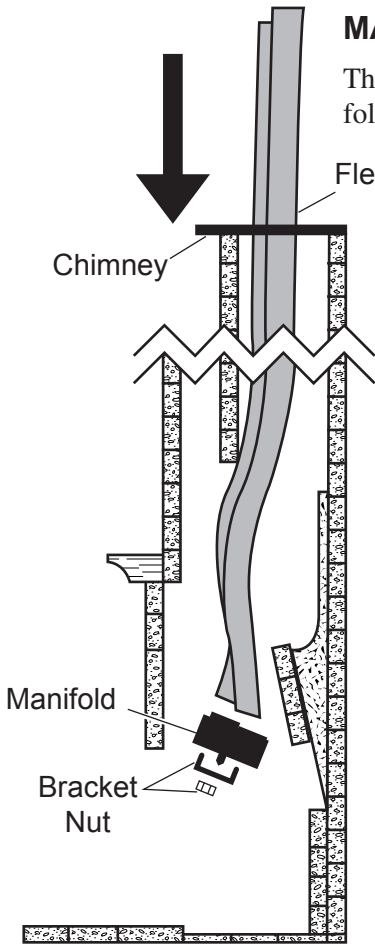

Figure 7 - Placing Manifold Into Fireplace

1. Remove brick liner and baffle.
2. Remove manifold. Place manifold in fireplace.
3. Route flex vent through chimney from above. See Figure 7. Leave an extra 3" (914mm) at the top.
4. Attach flex vent to manifold. See Figure 8. Seal with silicone and attach with screws.

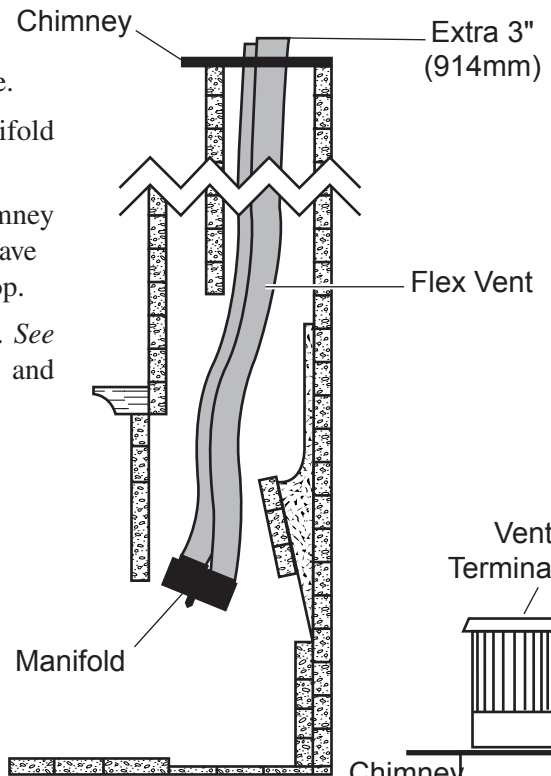

Figure 8 - Attaching Flex Vent to Manifold

5. Place manifold in an upright position. Have someone pull on the excess flex vent. Figure 9. Temporarily attach flex vent to top of chimney. Leave some extra slack in flex vent.

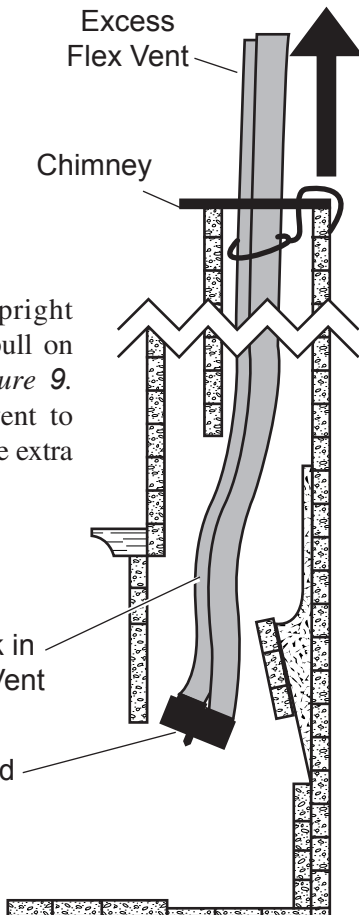

Figure 9 - Pulling On Excess Flex Vent

6. Slide insert into place. Guide the manifold over the insert until it is fully in place. Figure 10.
7. Remove any slack from flex vent. Attach manifold to insert. Figure 10.
8. Remove any excess slack in flex line. Attach vent termination. Figure 10.

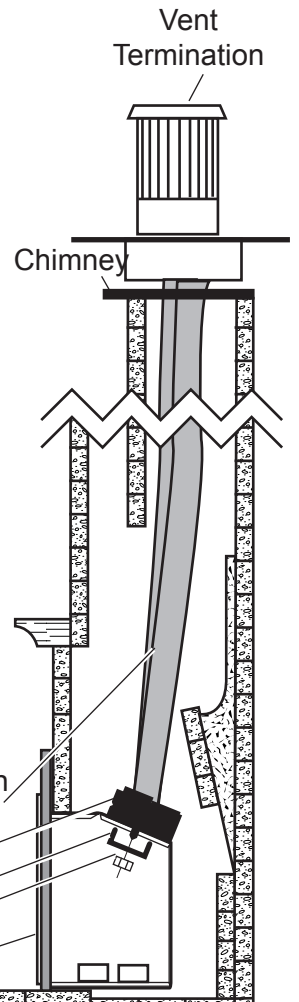

Figure 10 - Sliding Insert Into Place

9. Replace baffle and brick liner.

INSERT INSTALLATION

CHECK GAS TYPE

Use proper gas type for the insert you are installing. If you have conflicting gas type, do not install insert. See dealer where you purchased the insert for proper insert according to your gas type.

INSTALLING GAS PIPING TO INSERT LOCATION

WARNING

A qualified installer or service person must connect appliance to gas supply. Follow all local codes.

CAUTION

For propane/LP units, never connect insert directly to the propane/LP supply. This burner system requires an external regulator (not supplied). Install the external regulator between the burner system and propane/LP supply.

INSTALLATION ITEMS NEEDED

Before installing insert and burner system, make sure you have the items listed below.

- External regulator (supplied by installer)
- Piping (check local codes)
- Sealant (resistant to propane/LP gas)
- Test gauge connection*
- Sediment trap (optional but recommended)
- Tee joint
- Pipe wrench
- approved flexible gas line with gas connector (if allowed by local codes — not provided)

* A CSA design-certified equipment shutoff valve with $\frac{1}{8}$ " NPT tap is an acceptable alternative to test gauge connection. Purchase the CSA design-certified equipment shutoff valve from your dealer.

For propane/LP connections only, the installer must supply an external regulator. The external regulator will reduce incoming gas pressure. You must reduce incoming gas pressure to between 11 and 13 inches of water. If you do not reduce incoming gas pressure, burner system regulator damage could occur. Install external regulator with the vent pointing down as shown in *Figure 11*. Pointing the vent down protects it from freezing rain or sleet.

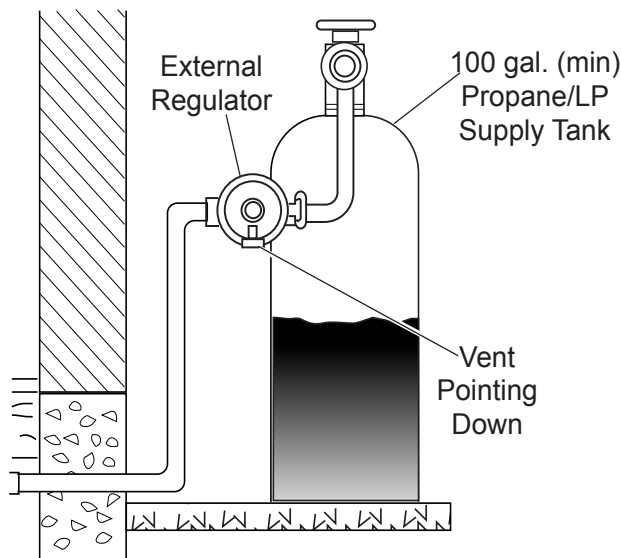

Figure 11 - External Regulator with Vent Pointing Down (Propane/LP Only)

CAUTION

Use only new black iron or steel pipe. Internally tinned copper or copper tubing can be used per National Fuel Code, section 2.6.3, providing gas meets hydrogen sulfide limits, and where permitted by local codes. Gas piping system must be sized to provide minimum inlet pressure (listed on data plate) at the maximum flow rate (BTU/hr). Undue pressure loss will occur if the pipe is too small.

When using copper or flex connectors use only fittings approved for gas connections. The gas control inlet is $\frac{3}{8}$ " NPT.

WARNING

Only persons licensed to work with gas piping may make the necessary gas connections to this appliance.

CAUTION

A manual shutoff valve is factory installed upstream of the appliance. Union tee and plugged $\frac{1}{8}$ " NPT pressure tapping point should be installed upstream of the appliance. See Figure 12.

NOTE : The gas line connection may be made using $\frac{1}{2}$ " rigid tubing or an approved flex connector. Since some municipalities have additional local codes it is always best to consult your local authorities and the current edition of the National Fuel Gas Code ANSI.Z223.1, NFPA54. In Canada CAN/CGA-B149 (1 or 2) Installation Code.

A listed manual shutoff is factory installed upstream of appliance. Union tee and plugged $\frac{1}{8}$ " NPT pressure tapping point should be installed upstream of the appliance. See Figure 12.

IMPORTANT: The main gas valve is for turning on or shutting off the gas to the insert.

Check your building codes for any special requirements for locating equipment shutoff valve to inserts.

Apply pipe joint sealant lightly to threads. This will prevent excess sealant from going into pipe. Excess sealant in pipe could result in clogged burner system valves.

CAUTION

Use pipe joint sealant that is resistant to liquid petroleum (LP) gas.

We recommend that you install a sediment trap/drip leg in supply line as shown in Figure 12. Locate sediment trap/drip leg where it is within reach for cleaning. Install in piping system between fuel supply and burner system. Locate sediment trap/drip leg where trapped matter is not likely to freeze. A sediment trap traps moisture and contaminants. This keeps them from going into the burner system gas controls. If sediment trap/drip leg is not installed or is installed wrong, burner system may not run properly.

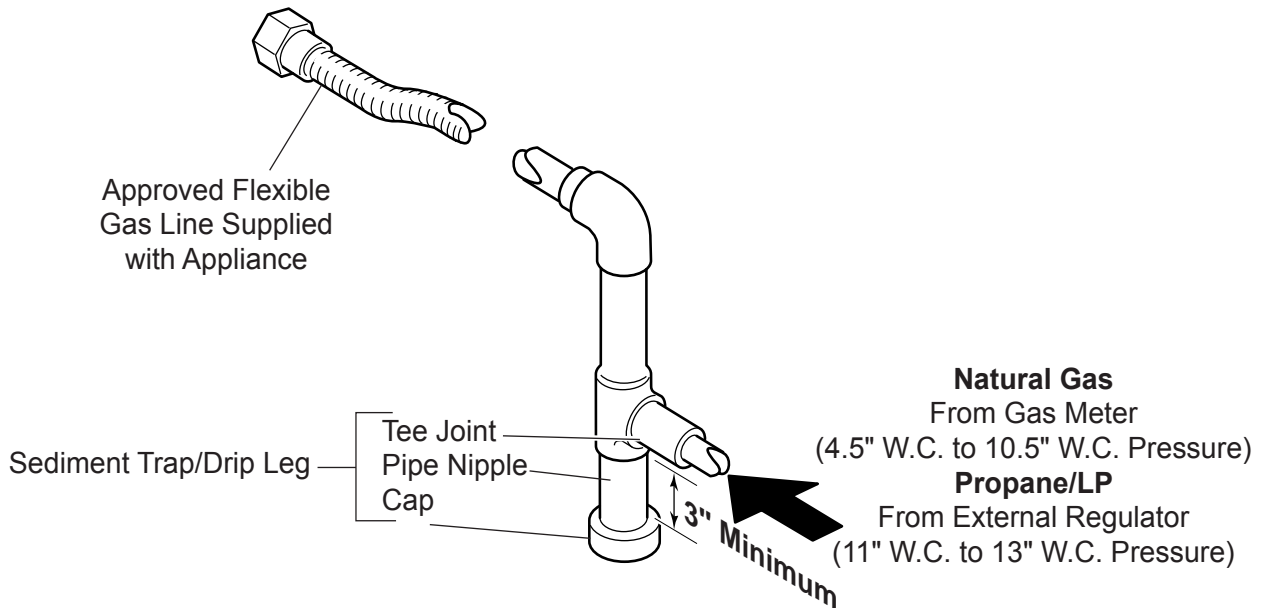

Figure 12 - Gas Connection

CHECKING GAS PRESSURE

The appliance and its main gas valve must be disconnected from the gas supply piping system during any pressure testing of that system at test pressures in excess of 1/2 psi (3.5 kPa). The appliance must be isolated from the gas supply piping system by closing its equipment shutoff valve during any pressure testing of the gas supply piping system at test pressures equal or less than 1/2 psi (3.5 kPa).

1. Check gas type. The gas supply must be the same as stated on the appliance's rating decal. If the gas supply is different from the fireplace, STOP! Do not install the appliance. Contact your dealer immediately.
2. To ease installation, a flex line with manual shut-off valve has been provided with this appliance. Install and attach 1/2" gas line onto shut-off valve.
3. After completing gas line connection, purge air from gas line and test all gas joints from the gas meter to the fireplace for leaks. Use a solution of 50/50 water and soap or a gas sniffer.
4. To check gas pressures at valve, turn captured screw counter clockwise 2 or 3 turns and then place tubing to pressure gauge over test point. Turn unit to high. See *Figure 13*. After taking pressure reading, be sure and turn captured screw clockwise firmly to reseal. Do not over torque. Check test points for gas leaks.

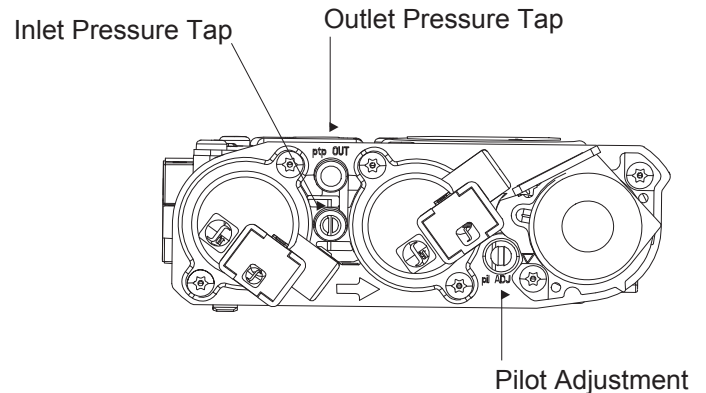

Figure 13 - Gas Pressure Check at Gas Valve

WARNING

Do not use open flame to check for gas leaks.

ELECTRICAL WIRING

This fireplace requires 110V AC electrical supply for normal operation in order to power up blower and 7V DC adapter which is required to operate Remote Control. However, during power outage situation, its electronic system (DFC board) can be temporarily powered with 6V DC battery pack (4 AA batteries).

WARNING

Electrical connections should only be performed by a qualified, licensed electrician. Main power must be off when connecting to main electrical power supply or performing service. All wiring shall be in compliance with all local, city, and state codes. The appliance, when installed, must be electrically grounded in accordance with local codes, or in the absence of local codes, with the *National Electrical Code ANSI/ NFPA 70 (latest edition)* and *Canadian Electrical Code, CSA C22.1*.

CAUTION

Label all wires before disconnecting when servicing controls. Wiring errors can cause improper and dangerous operation.

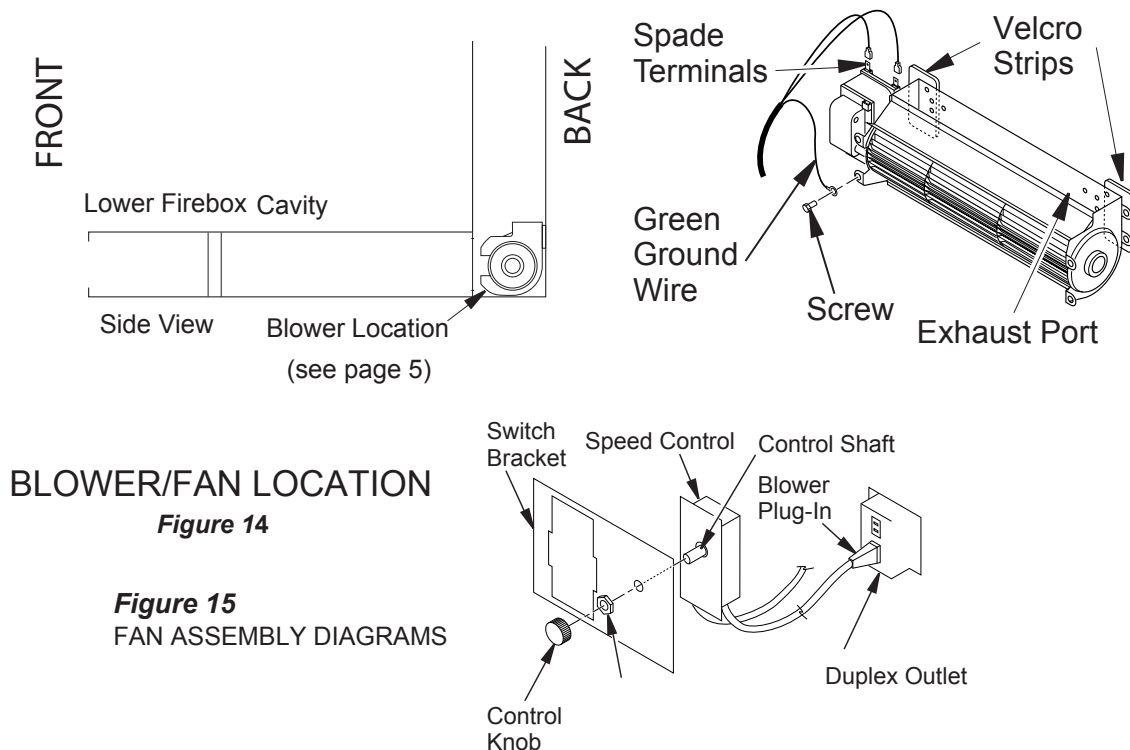

Figure 14

Figure 15
FAN ASSEMBLY DIAGRAMS

WARNING Electrical Grounding Instructions

The appliance is equipped with a three-prong (grounding) plug for your protection against shock hazard and should be plugged into a properly grounded three-prong receptacle. Do not cut or remove the grounding prong from this plug.

GLASS MEDIA AND OPTIONAL STONE PLACEMENT

WARNING

The positioning of the optional stones is critical to the safe and clean operation of this heater. Sooting and other problems may result if the stones are not properly positioned in the appliance. Never add additional stones or embellishments such as pine cones or vermiculite to the heater. Only use the stones supplied with the unit.

Failure to position the parts in accordance with diagrams below or to use only parts specifically approved for this heater may result in property damage or personal injury.

GLASS MEDIA PLACEMENT IN THE FIREBOX

1. Remove the glass door from the firebox.
2. If optional stones are not provided, cover entire burner and surrounding area with supplied glass media as shown. Avoid blocking pilot area with excess of media.



INSTALLING OPTIONAL STONES AND GLASS MEDIA IN THE FIREBOX

1. Remove the glass door from the firebox.
2. Place the first five stones (the smallest in size) as shown below. *IMPORTANT: Avoid ports when placing stones on the burner.*



3. Cover entire burner around the stones as well as surrounding area with the supplied glass media as shown. Avoid blocking pilot area with excess of media.



STONE PLACEMENT

8. Set eight (8) larger stones along the burner surround as shown.



NOTE: Use only original Woodbridge Fireplace replacement parts.

CAUTION

Always use gloves when handling broken glass.

WARNING

Make sure the glass panel edges do not touch any metal parts during thermal expansion.

1. Remove three nuts, washers and springs.

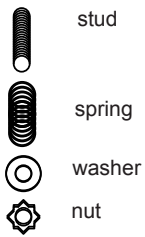

2. Carefully remove the glass door. See Figure 16.
3. Install the replacement glass door (Part # A100036).

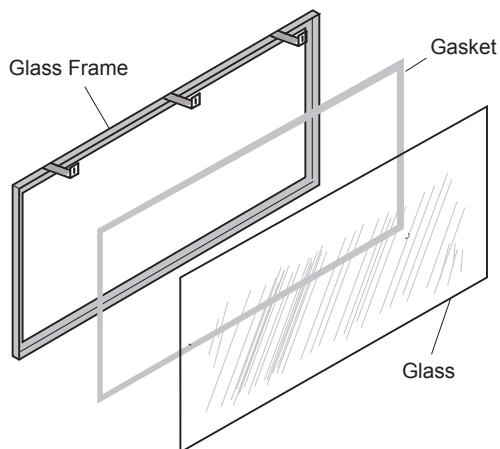

Figure 17 - Glass Door Assembly

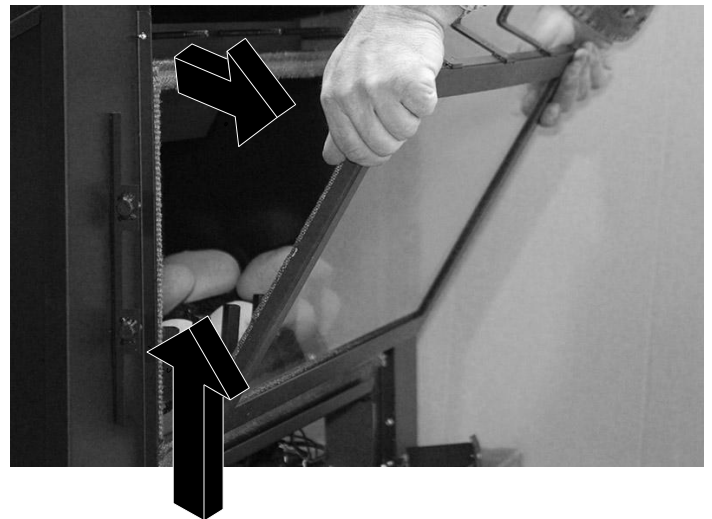

Figure 16 - Removing Glass Door

4. Replace the springs, washers, and nuts as shown. Tighten the nuts until they are flush with the end of the studs. Do NOT over tighten.



INSTALLING SURROUND AND OUTER FACE

1. Fasten the surround to the firebox using 4 screws provided (two on each side).

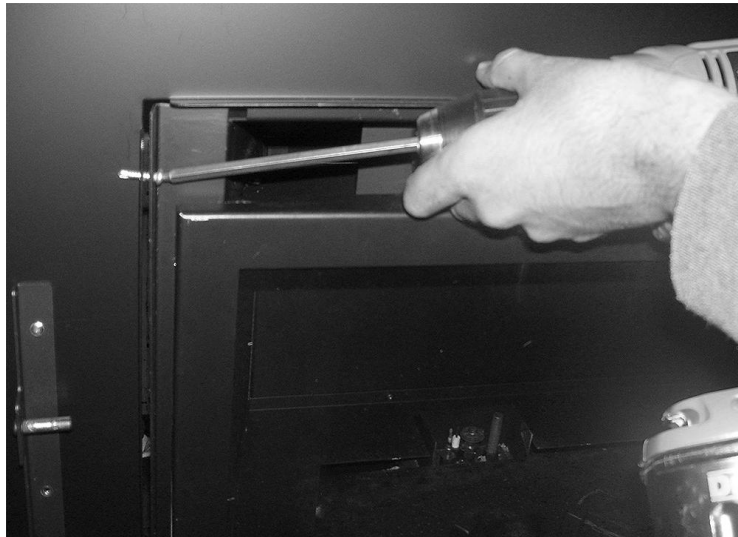

NOTICE

Before installing the facing remove all fingerprints from the glass door and facing with a 50/50 vinegar and water solution. Any fingerprints left on the glass or the facing will be permanent when heater is lit.

2. Locate the vertical hooks on both sides at the back of the outer face.
3. Place the outer face in front of the appliance and align the hooks with the horizontal pins.
4. Position the outer face so the hooks are going over the horizontal pins and then allow the face to drop down firmly inside the slots.



Figure 18 - Installing Outer Face

LIGHTING FOR THE FIRST TIME

NOTE: Remove any excessive pipe compound from the connections. Excessive pipe compound can set off electronic sniffers.

Check for gas leaks in each of the following locations:

- Pipe from the gas supply line connection to the gas valve
- Burner connections, pilot
- All joints on valve and control body
- Field made joints / gas shutoff valve
- Factory made joints, each joint and connection

TO TURN OFF GAS TO APPLIANCE

1. Turn off all electric power to the appliance if service is to be performed. Unplug 7V DC adapter from the power outlet.
2. If necessary, remove access panel from the appliance to access manual shutoff valve on gas line.
3. Open access panel. Turn the manual gas shutoff valve clockwise  to the full OFF position.
4. If necessary, close access panel.

OPERATING INSTRUCTIONS

1. **STOP! Read the safety information**
2. Turn off all electric power to the appliance.
3. Do not attempt to light the pilot by hand.
4. Open access panel (See *Illustrated Parts List* in Owner's Manual).
5. Turn the gas control manual valve clockwise  to the full OFF position
6. Wait five (5) minutes to clear out any gas. Then smell for gas, including near the floor.

If you smell gas, Stop! Follow "B" in the safety information.

If you don't smell gas, go to the next step.

7. Turn the gas control manual valve counterclockwise  to the ON position.
8. Plug supplied 7V DC adapter into 110V power outlet.
9. Connect the wire to the DC input plug at the unit.
10. Turn on all electric power to the appliance.
11. Locate Remote Receiver inside of the unit (See *Illustrated Parts List*).
Make sure that the slider switch of the Receiver is in "REMOTE" (middle) position.

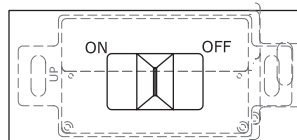

12. Close access panel
13. Read and follow instructions in how to set up and to use remote control described in supplied "Use and Installation Instructions for the Remote Control."
14. If the appliance will not operate, follow the instructions "To Turn Off Gas To Appliance" and call you service technician or gas supplier.

OPERATING INSTRUCTIONS

REMOTE CONTROL OPERATION

⚠ CAUTION: Do not try to adjust heating levels by using the equipment shutoff valve.

⚠ WARNING: Make sure the remote receiver switch is in the OFF position when you are away from home for long periods of time. Heater may come on automatically with remote receiver switch in the "REMOTE" position.

Initializing the System for the First Time

1. Install the 4 AA batteries into the receiver battery bay. Note the polarity of the batteries and insert into the battery bay as indicated on the battery cover (+/-).
2. Place the 3-position slider switch in the REMOTE position.
3. Insert the end of a paper clip into the hole marked PRG on the receiver front cover. The receiver will beep three times to indicate that it is ready to synchronize with a transmitter.
4. Install the 3 AAA batteries in the transmitter battery bay located on the base of the transmitter.
5. Press the ON button on the transmitter. The receiver will beep four times to indicate the transmitter's command is accepted. The system is now initialized.

Temperature Indication Display

1. With the system in the OFF position, press the THERMOSTAT key and the MODE key at the same time.
2. Look at the LCD screen on the transmitter to verify that a °C or °F is visible next to the room temperature.



Blue LCD display

ON/OFF Key

THERMOSTAT Key

UP/DOWN Arrow

Key MODE Key

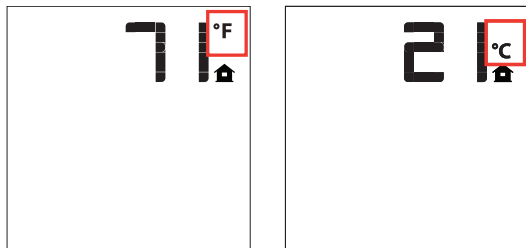

Figure 20 - Remote Control Display in Fahrenheit and Celsius

Turning ON the Appliance

1. Press the ON/OFF button on the transmitter. The transmitter screen will display all active icons. The receiver will command the DFC board to start the ignition process. Once the pilot flame is lit, the DFC board will open the main valve outlet and the main burner will ignite. A single "beep" from the receiver will confirm the command.

Turning OFF the Appliance

1. Press the ON/OFF button on the transmitter. The transmitter LCD display will only show the room temperature and icon (see Figure 20b). The receiver disconnects and will command the DFC board to turn off the burner.

A single "beep" from the receiver will confirm the command.

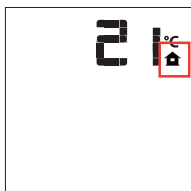

Figure 20b - Remote Control Displaying Room Temperature

Flame Height Control

Proflame GTM

These units have six flame levels (see Figure 21).

1. With the system ON and the flame level at maximum height, press the down-arrow key once to reduce the flame height by one step. Continue pressing down-arrow key until flame is turned OFF.

2. Press the up-arrow key to increase the flame height.

Note: If you press the up-arrow key while the remote system is ON but the flame is OFF, the flame will come on in the high position. A single "beep" from the receiver will confirm the command.

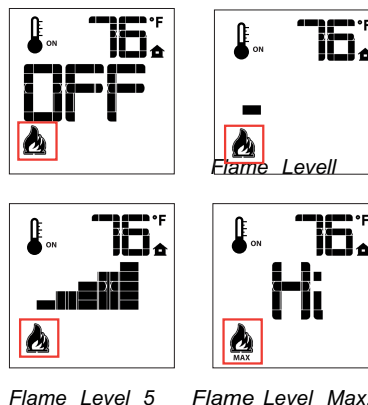

Figure 21 - Remote Control Displaying Flame Levels

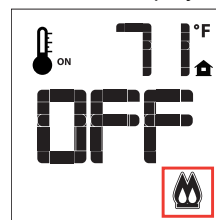

Figure 21b - Remote Control Displaying Split Flow Mode

Room Thermostat (Transmitter Operation)

The remote control can operate as a room thermostat. The thermostat can be set to a desired temperature to control the comfort level in the room.

1. To activate this function, press the Thermostat key. The LCD display on the transmitter will change to show that the room thermostat is ON and the set temperature is now displayed (see Figure 22).
2. Adjust the set temperature by pressing the up or down-arrow keys until the desired set temperature is displayed on the LCD screen (see Figure 22).

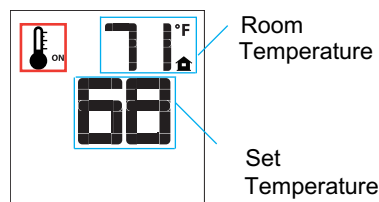

Figure 22 - Remote Control Displaying Room Temperature and Set Temperature

OPERATING INSTRUCTIONS

Smart Thermostat (Transmitter Operation" Proflame GTM)

The Smart Thermostat function adjusts the flame height in accordance to the difference between the set point temperature and the actual room temperature. As the room temperature gets closer to the set point, the Smart Function will modulate the flame down.

1. To activate this function, press the Thermostat key until the word "SMART" appears to the right of the temperature bulb on the LCD screen (see Figure 23).
2. To adjust the set temperature, press the up or down-arrow keys until the desired set temperature is displayed on the LCD screen.

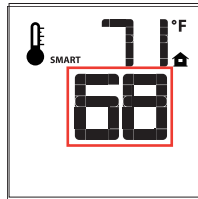

Figure 23 - Remote Control Displaying Smart Thermostat Function

Key Lock

This function will lock the keys to avoid unsupervised operation.

1. To activate this function, press the MODE and UP keys at the same time. A lock icon will appear on the LCD screen (see Figure 24).
2. To deactivate this function, press the MODE and UP keys at the same time. The lock icon will disappear from the LCD screen.

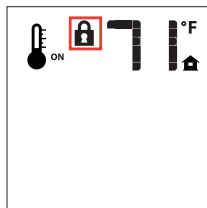

Figure 34 - Remote Control Displaying Key Lock Mode

Low Battery Power Detection Receiver

The life span of the receiver batteries depends upon various factors: battery quality, Number of appliance ignitions, number of thermostat set point changes, etc.

When the receiver batteries are low, no "beep" will sound from the receiver when a transmitter command is sent. Replace batteries when this happens,

Transmitter

The life span of the transmitter batteries depends upon various factors: battery quality, number of appliance ignitions, number of thermostat set point changes, etc.

When the transmitter batteries are low, an icon will appear on the LCD display (see Figure 24a), Replace batteries when this icon appears.

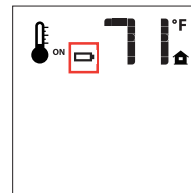

Figure 24a - Remote Control Displaying Low Battery

Manual Override

If the receiver or transmitter batteries are low or depleted, the appliance can still be turned on manually.

1. Move the receivers three-position slider to the ON position. This will bypass the remote control feature of the system and the appliance main burner will turn on.

Command Definitions

Pilot IPI / CPI switch	Position of the receiver slider switch	Command reference name	Commanded Fireplace State
Opened, IPI	"OFF" / "REMOTE" and "OFF received"	Turn-OFF	Flames OFF
Opened, IPI	"ON" / "REMOTE" and "ON received"	Turn-ON	Pilot + Main burner flames ON
Closed, CPI	"OFF" / "REMOTE" and "OFF received"	Pilot-ON	Pilot flame ON
Closed, CPI	"ON" / "REMOTE" and "ON received"	Turn-ON	Pilot + Main burner flames ON

CLEANING AND MAINTENANCE

Make sure the gas valve knob is in the “OFF” position. Wait at least five (5) minutes before starting maintenance.

VENTING SYSTEM

A qualified agency should examine the venting system annually.

CLEANING GLASS

Clean the ceramic glass periodically. Condensation will sometimes form on the glass during a cold startup. This is normal for all gas fireplaces and inserts. This condensation often attracts dust and lint to the surface of the glass. The initial paint curing of the appliance can also leave a slight film on the glass. This is a temporary problem. You should clean the glass after the first two weeks of use. After that, you should clean the glass no more than two or three times a season. Use a mild glass cleaner to clean the door.

WARNING: Do not use abrasive cleaners. They will damage the glass surface.

PILOT AND BURNER FLAMES

Visually check pilot and burner flame periodically. See Figure 25 for typical burner flame. There is no air adjustment on the main burner. The air shutter is preset at the factory. See Figure 26 for typical pilot flame.



Figure 25- Typical Burner Flame

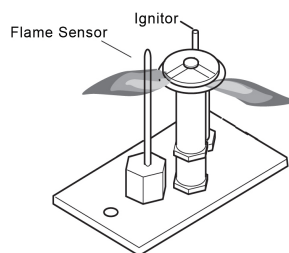

Figure 26 - Typical Pilot Flame

AIR SHUTTER ASSEMBLY

Air shutter is adjusted at factory: $\frac{3}{16}$ " for natural gas and fully open with two additional $\frac{3}{8}$ " dia. holes for propane gas. If necessary, change this by loosening nut and opening or closing the air shutter more.

FIREBOX CLEANING

1. Carefully remove log set, and embers from combustion chamber.
2. Vacuum burner compartment thoroughly.
3. Vacuum any dust off logs.
4. Remove any lint from main burner and pilot.
5. Carefully replace log set, and embers in their correct positions. *See pages 18 through 21.*
6. Replace door (if it has been removed).
7. Relight pilot. *See page 25.*
8. Turn on main burners.

Any parts that need to be replaced must be ordered from the manufacturer. Do not use substitute materials.

WARNING

Make sure that clearances to combustibles leave enough room for maintenance and service.

WARNING

Carefully reassemble and reseal insert properly after any cleaning or servicing.

MAINTENANCE

MAINTAINING YOUR HEATER'S APPEARANCE

Fingerprints or other marks left on optional gold or nickel surface may become etched in place if they are not wiped clean prior to turning stove on. Clean gold or nickel with a 50/50 vinegar and water solution and soft cloth soft cloth.

NOTE: Make sure heater is cool before cleaning. Using cleaners other than a 50/50 vinegar and water solution may leave a film that becomes permanently etched into the gold or nickel.

YEARLY SERVICE PROCEDURE

Failure to inspect and maintain heater may lead to improper combustion and a potentially dangerous situation. A qualified technician should do the following once a year.

1. Check pilot flame. Flame should touch approximately $\frac{3}{8}$ " of the top of Flame Sensor and Ignitor. *See Figure 27.* If not, contact dealer for service.
2. Turn remote control to "OFF position to shut off gas to the heater." See step "To Turn Off Gas", page 24. Let heater cool for 15 minutes. Remove faceplate (see instructions included with face plate) and glass door. *See page 21-22.*
3. Carefully remove stone set. If stones are severely deteriorated, replace stones. Check stones for sooting. A small amount of soot along bottom of stones is normal. If excessive sooting is found, heater must be adjusted. Contact dealer where you bought heater.
4. Clean burner and burner ports. Inspect the following. *See Figure 28:*
 - Check burner ports for cracks, warpage and corrosion.
 - Make sure burner assembly is not warped or damaged.
 - Check firebox and area around pilot to make sure there is no warping or damage.

If any problem is found, do not use heater. Contact your dealer for service.

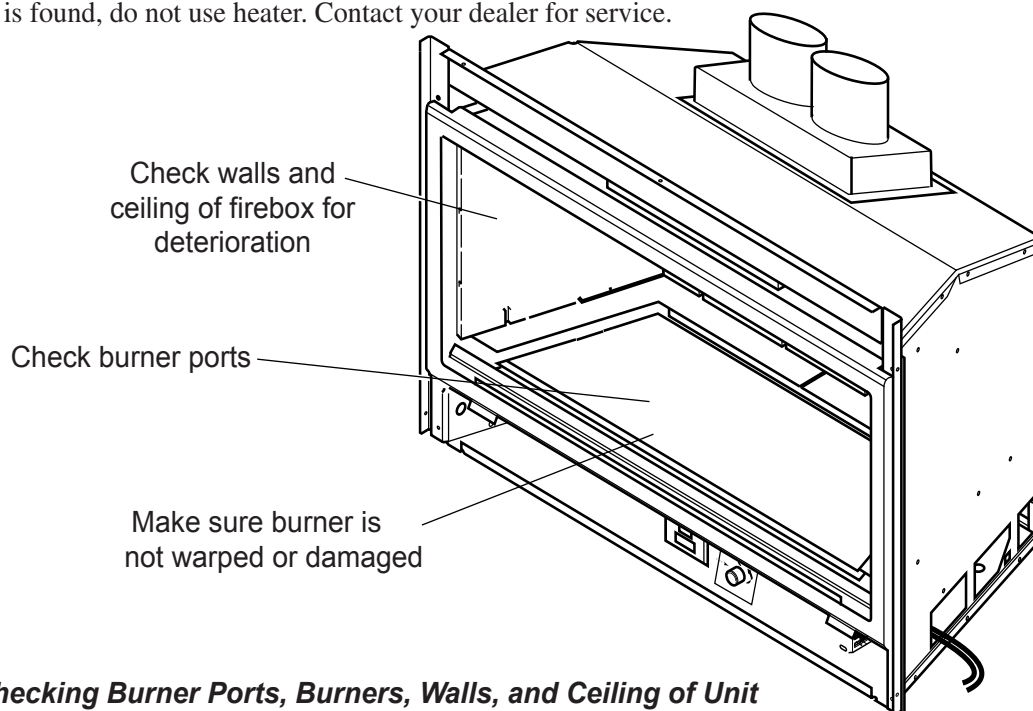

Figure 28 - Checking Burner Ports, Burners, Walls, and Ceiling of Unit

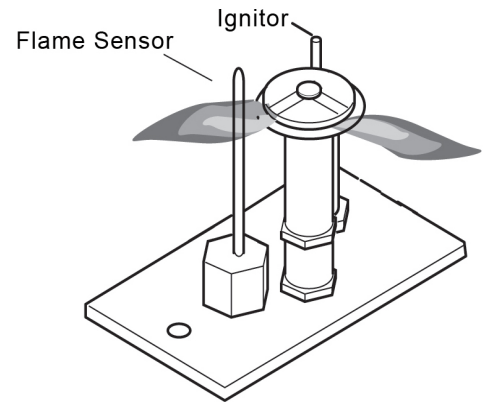

Figure 27 - Before taking unit apart, check pilot flame. Flame should touch Flame Sensor and Ignitor.

Continued on Next Page

5. Replace stone set and glass media per instructions on pages 18-20. Replace glass. Make sure gasket along perimeter of glass contacts face of firebox and forms an airtight seal. Realign if airtight seal is not formed. Replace glass and glass frame if damaged.
6. Inspect area behind access door. Clean if necessary. Check gas control valve and all gas lines. If damaged, do not use heater. Contact your dealer.
7. Start pilot and turn on main burner. Flames should be orange/yellow and not touch top of firebox. If pilot or main burner do not burn correctly, contact your dealer for service. Monitor blower operation.

BLOWER

ADJUSTING BLOWER SPEED

The internal blower helps transfer heat from heater into room. It will not turn on until heater is up to temperature (approximately 10 minutes after starting).

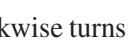
To turn blower off, turn knob all the way counter-clockwise . One click clockwise turns blower to high speed. Turning knob clockwise  from high position decreases speed of blower.

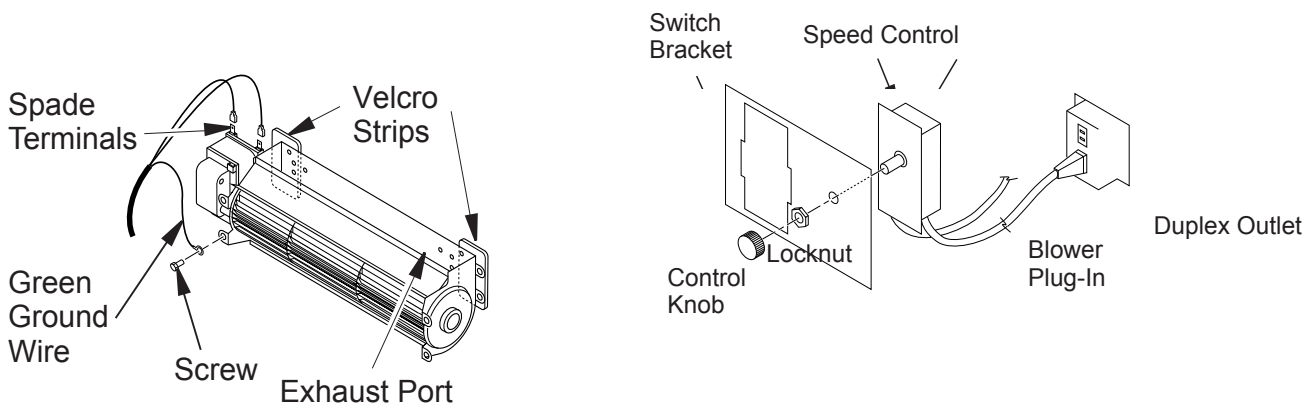
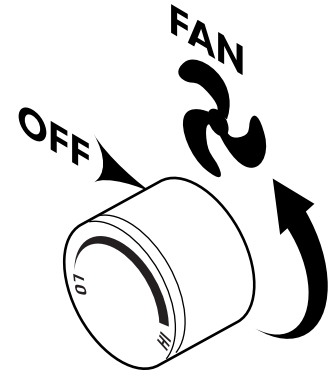

NOTE: Unplug powercord before servicing. The blower is attached to the insert bottom and back with Velcro. To remove blower for servicing, pull away from Velcro and disconnect wires.

CAUTION: Label all wires prior to disconnection when servicing controls. Wiring errors can cause improper and dangerous operation. Verify proper operation after servicing.

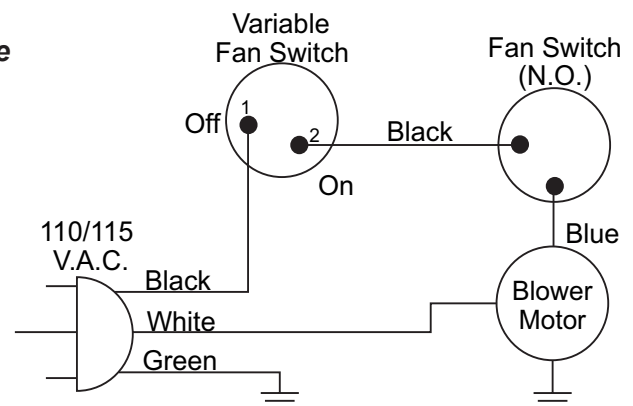
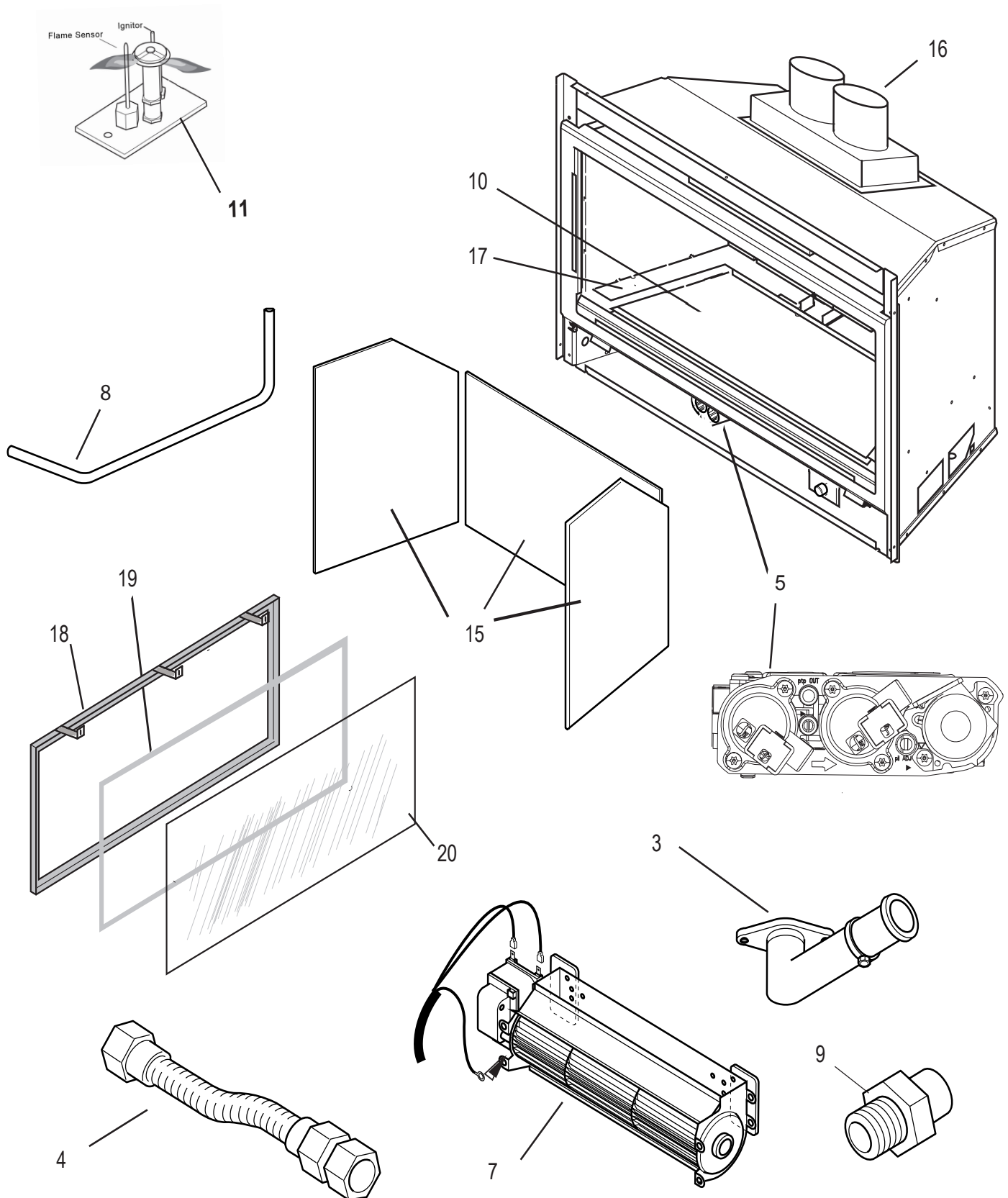

Figure 29 - Fan wire assembly diagram

REPLACEMENT PARTS



Continued on Next Page

13 pcs Optional Stone Set (Part Number G100007):

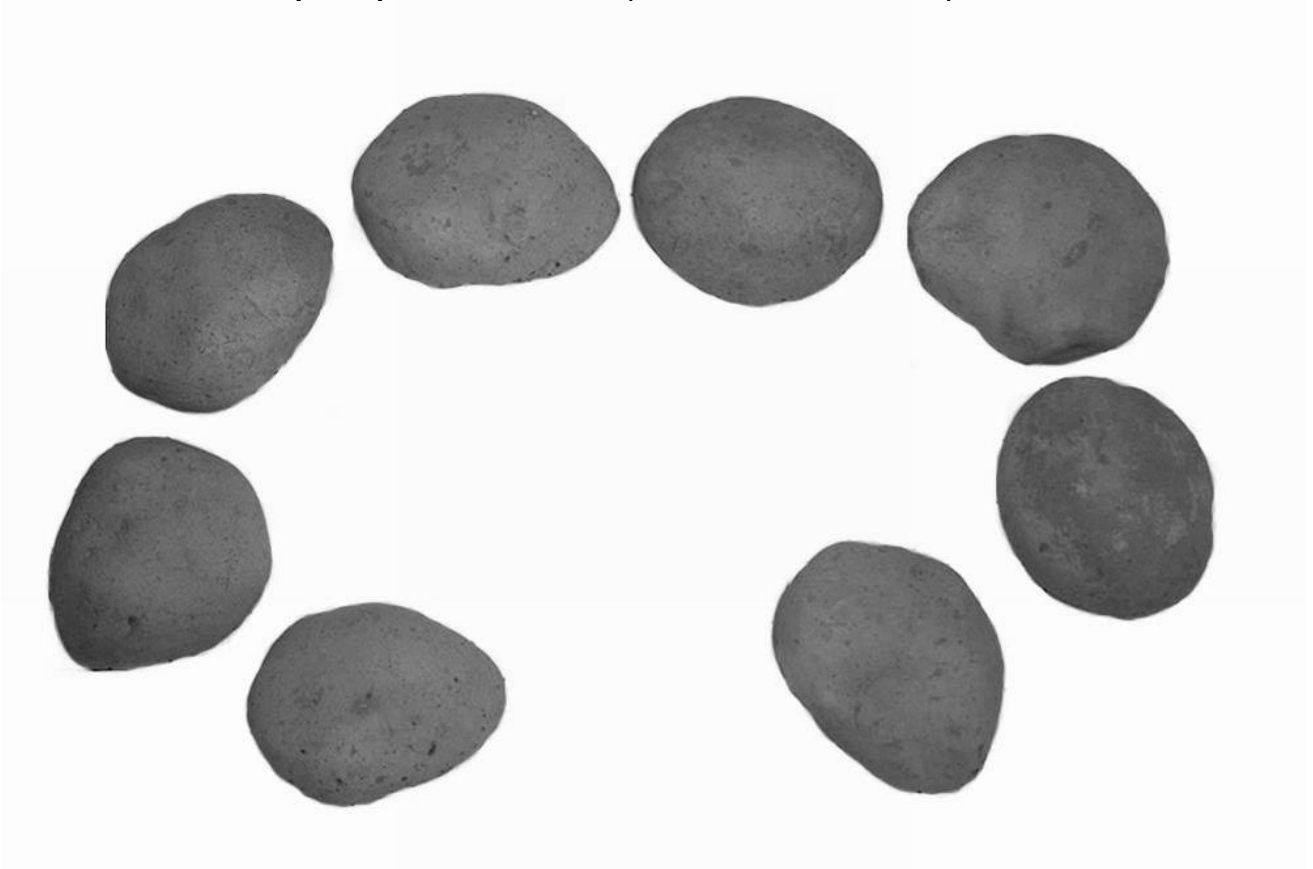

Back Row Larger Stones



Front Row Smaller Stones

Continued on Next Page

REPLACEMENT PARTS

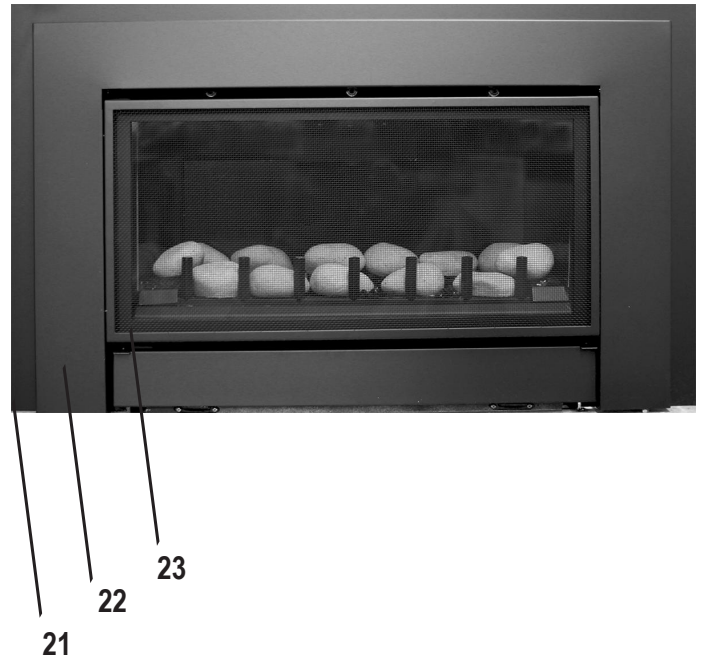
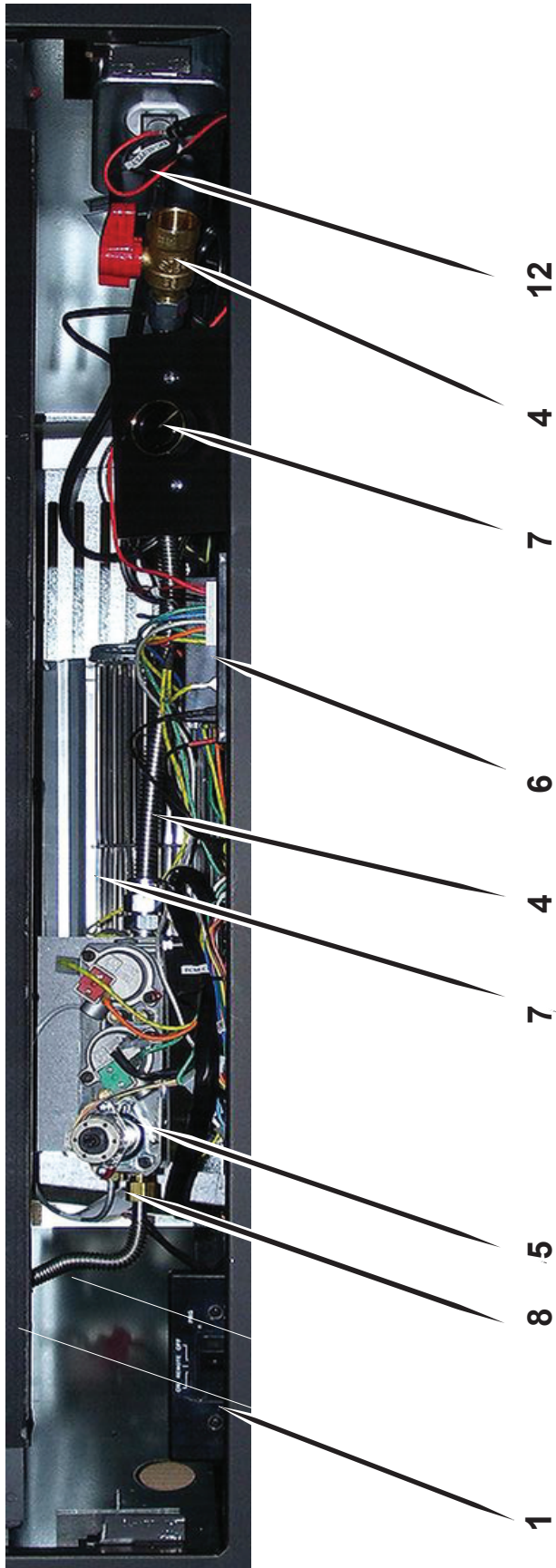

Proflame Wiring Diagram

This diagram shows replaceable SIT Proflame parts used in your fireplace

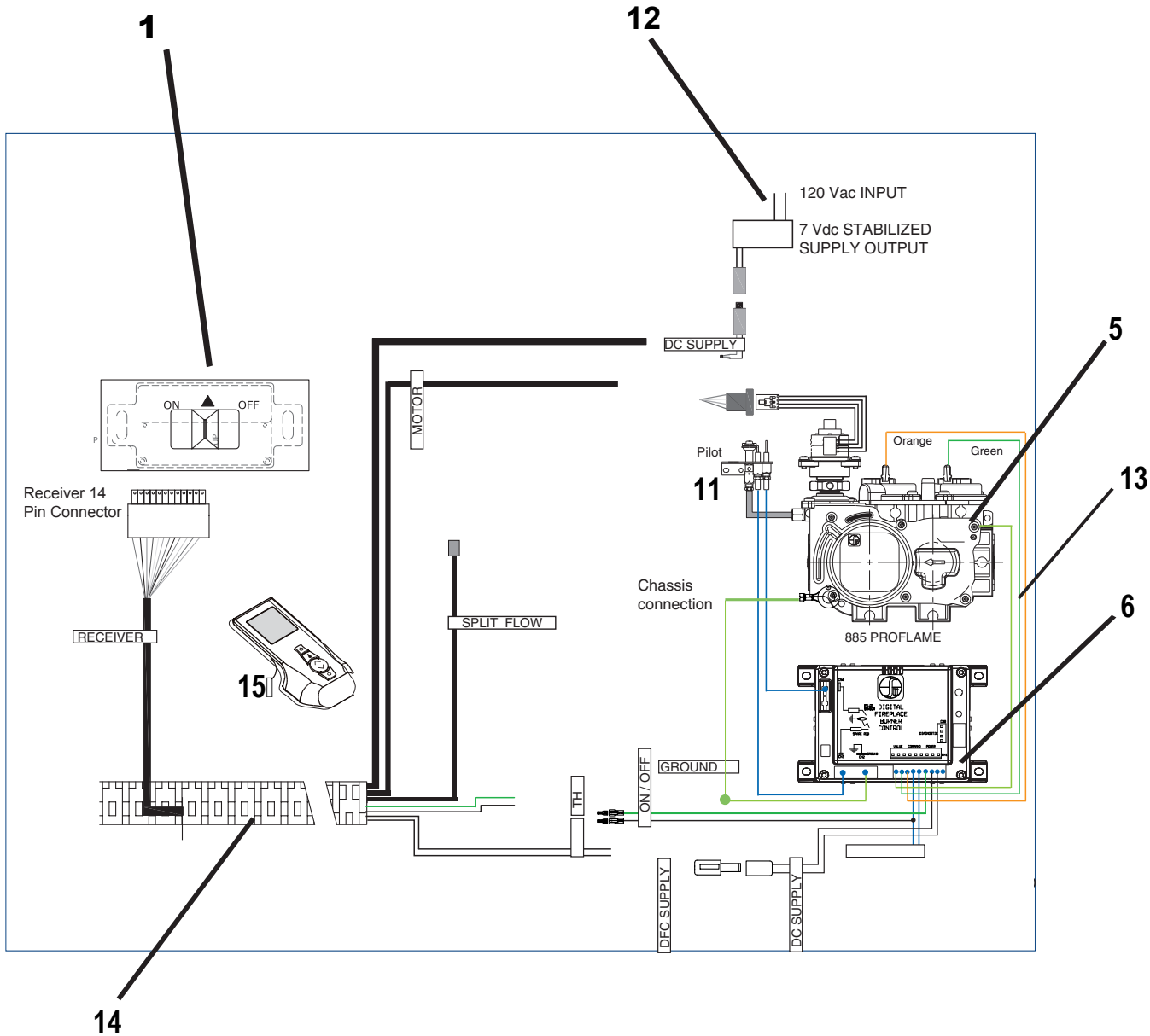

PARTS LIST

This list contains replaceable parts used in your firebox.
 All replacement parts should be ordered from your installer or from Woodbridge Fireplace Inc.
 at 1-905-564-3001 or on-line at www.woodbridgefp.com

KEY No.	PART NUMBER		DESCRIPTION	QTY
	DVI 751N-E	DVI 751P-E		
1	H200010	H200010	REMOTE CONTROL RECEIVER	1
2	H200001	H200001	GTM REMOTE CONTROL	1
3	C100008	C100008A	VENTURI	1
4	C100009	C100009	24" FLEX CONNECTOR WITH SHUTOFF VALVE	1
5	C200001	C200002	MAIN GAS VALVE	1
6	H100142	H100142	ELECTRONIC CONTROL DFC BOARD	1
7	A100014	A100014	THERMOSTAT, BLOWER WITH SPEED CONTROL	1
8	C100037	C100037	BURNER FLEX TUBE CONNECTOR	1
9	E100111	E100112	ORIFICE	1
10	W500025	W500023	BURNER ASSEMBLY	1
11	C200003	C200004	PILOT ASSEMBLY	1
12	H100140	H100140	7V 10mA DC ADAPTER	1
13	H200012	H200012	DFC TO CPI WIRE HARNESS	1
14	H200011	H200011	GTMFS WIRE HARNESS	1
15	E300033	E300033	REFLECTIVE ENAMELLED PANELS	1
16	W100100	W100100	VENT MANIFOLD	1
17	E200020	E200020	LOG SUPPORT	1
18	W200027	W200027	GLASS FRAME*	1
19	I100015	I100015	GLASS FRAME GASKET*	1
20	G100008	G100008	CERAMIC GLASS*	1
21	W200011	W200011	INSERT FACE SURROUND	1
22	W200014	W200014	INSERT OUTER FACE	1
23	W200017	W200017	INSERT SAFETY SCREEN	1

*** NOTE: The glass frame assembly shall only be replaced as a complete unit as supplied by the manufacturer (Part # A100036).**

WARNING

Turn appliance OFF and allow to cool before servicing. Only a qualified service person should service and repair the heater.

Note: All troubleshooting items are listed in order of operation.

- | | | |
|---|---|---|
| 1. Spark ignitor will not light pilot | <ul style="list-style-type: none"> A. Wire disconnected. B. Defective ignitor. C. No gas or low gas pressure. D. No Propane/LPG in tank | <ul style="list-style-type: none"> A. Open door and check to make sure wire is connected to ignitor. B. Check for spark at electrode and pilot. If no spark and electrode wire is properly connected, replace pilot assembly. C. Check remote/manual shut off valve from fireplace. Low pressure can be caused by bent lines, restricted lines, low pressure line pressure. Consult with plumber or gas supplier. D. Check Propane/LPG tank. Refill tank. |
| 2. Frequent pilot outage problem. | <ul style="list-style-type: none"> A. Pilot flame may be too low, causing pilot safety to drop out | <ul style="list-style-type: none"> A. Clean and adjust the pilot flame for maximum flame impingement on flame sensor. |
| 3. The pilot and main burner extinguish while in operation | <ul style="list-style-type: none"> A. Inner vent pipe leaking exhaust gases back into system B. Horizontal vent improperly pitched C. Improper vent cap installation | <ul style="list-style-type: none"> A. Check for flue product leak. Replace defective pipe section. B. Check horizontal-venting piping is running upward 1/4" per foot. Do not run the pipe level or downward. C. Check for proper installation and freedom from debris or blockage. |
| 4. Flame burn blue and lifts off burner (ghosting) | <ul style="list-style-type: none"> A. Insufficient oxygen being supplied | <ul style="list-style-type: none"> A. Ensure that the vent cap is installed properly and free of debris. Ensure that the vent system joints are tight and have no leaks. Ensure that no debris has been blocking the inner air intake at the bottom back of the combustion chamber. Ensure that the glass is properly secure and latch. |



LIFETIME WARRANTY

The following components are warranted for life to the original owner, subject to proof of purchase: Firebox, Combustion Chamber, Heat Exchanger, Grate and Steel Burners.

FIVE YEAR WARRANTY

The following components are warranted five (5) years to the original owner, subject of proof of purchase: Ceramic Stones.

BASIC WARRANTY

Woodbridge Fireplace Inc. warrants the components and materials in your gas appliance to be free from manufacturing and material defects for a period of two years from date of installation. After installation, if any of the components manufactured by Woodbridge Fireplace Inc. in the appliance are found to be defective in materials or workmanship, Woodbridge Fireplace Inc. will, at its option, replace or repair the defective components at no charge to the original owner. Woodbridge Fireplace Inc. will also pay for reasonable labor costs incurred in replacing or repairing such components for a period of two years from date of installation. Any products presented for warranty repair must be accompanied by a dated proof of purchase.

This Limited Lifetime Warranty will be void if the appliance is not installed by a qualified installer in accordance with the installation instructions. The Limited Lifetime Warranty will also be void if the appliance is not operated and maintained according to the operating instructions supplied with the appliance, and does not extend to (1) firebox/burner assembly damage by accident, neglect, misuse, abuse, alterations, negligence of others, including the installation thereof by unqualified installers, (2) the costs of removal, reinstallation or transportation of defective parts on the appliance, or (3) incidental or consequential damage. All service work must be performed by an authorized service representative.

This warranty is expressly in lieu of other warranties, express or implied, including the warranty of merchantability of fitness for purpose and of all other obligations or liabilities. Woodbridge Fireplace Inc. does not assume for it any other obligations or liabilities in connection with sale or use of the appliance. It states that do not allow limitations on how long an implied warranty lasts, or do not allow exclusion of indirect damage, those limitations of exclusions may not apply to you. You may also have additional rights not covered in the Limited Lifetime Warranty.

Woodbridge Fireplace Inc. reserves the right to investigate any and all the claims against the Limited Lifetime Warranty and decide upon method of settlement.

For information about this warranty, contact:

Woodbridge Fireplace Inc.
1305 Meyerside Dr., Mississauga
Ontario, Canada L5T 1C9
Tel.: 1-905-564-3001
www.woodbridgedealer.com