

# Woodbridge Fireplace Inc.



Tested &  
Listed By  
**O-TL**  
C US  
Portland  
Oregon USA  
OMNI-Test Laboratories, Inc.  
Report # 0401GN010S

## DIRECT VENT GAS INSERT MODEL DVI 751T(N,P) INSTALLATION AND OPERATING INSTRUCTIONS

### **WARNING: FIRE OR EXPLOSION HAZARD**

Failure to follow safety warnings exactly could result in serious injury, death, or property damage.

- Do not store or use gasoline or other flammable vapors and liquids in the vicinity of this or any other appliance.
- **WHAT TO DO IF YOU SMELL GAS**
  - Do not try to light any appliance.
  - Do not touch any electrical switch; do not use any phone in your building.
  - Leave the building immediately.
  - Immediately call your gas supplier from a neighbor's phone. Follow the gas supplier's instructions.
  - If you cannot reach your gas supplier, call the fire department.
- Installation and service must be performed by a qualified installer, service agency or the gas supplier.

**WARNING:** Improper installation, adjustment, alteration, services or maintenance can cause injury or property damage. Refer to this manual. For assistance or additional information consult a qualified installer, service agency or the gas supplier.

This appliance may be installed in an aftermarket, permanently located, manufactured home (USA only) or mobile home where not prohibited by local codes.

This appliance is only for use with the type of gas indicated on the rating plate. This appliance is not convertible for use with other gases, unless a certified kit is used.

### **DANGER**



**HOT GLASS WILL CAUSE BURNS.**  
**DO NOT TOUCH GLASS UNTIL COOLED.**  
**NEVER ALLOW CHILDREN TO TOUCH GLASS.**

A barrier designed to reduce the risk of burns from the hot viewing glass is provided with this appliance and shall be installed for the protection of children and other at-risk individuals.

**DUE TO HIGH TEMPERATURES, THE APPLIANCE SHOULD BE LOCATED OUT OF TRAFFIC AND AWAY FROM FURNITURE AND DRAPERIES.**

**CHILDREN AND ADULTS SHOULD BE ALERTED TO THE HAZARDS OF HIGH SURFACE TEMPERATURE AND SHOULD STAY AWAY TO AVOID BURNS OR CLOTHING IGNITION.**

**YOUNG CHILDREN SHOULD BE SUPERVISED WHEN THEY ARE IN THE SAME ROOM AS THE APPLIANCE.**

**CLOTHING OR OTHER FLAMMABLE MATERIAL SHOULD NOT BE PLACED ON OR NEAR THE APPLIANCE.**

**KEEP THE ROOM AREA CLEAR AND FREE FROM COMBUSTIBLE MATERIALS, GASOLINE, AND OTHER FLAMMABLE VAPORS AND LIQUIDS.**

**INSTALLER:** Leave this manual with the appliance.  
**CONSUMER:** Retain this manual for future reference.

Version française de ce manuel est disponible à partir du site WEB : [www.woodbridgedealer.com](http://www.woodbridgedealer.com)

French version of this Owners Manual is available at [www.woodbridgedealer.com](http://www.woodbridgedealer.com)

---

# CONTENTS

---

<b>Important Safety Information</b> .....	<b>3</b>	<b>Media and Stone Set Placement</b> .....	<b>18</b>
<b>Product Specification</b> .....	<b>5</b>	<b>Glass replacement</b> .....	<b>21</b>
<b>Code Approval</b> .....	<b>5</b>	<b>Installing facing</b> .....	<b>22</b>
<b>Pre-Installation Information</b>		<b>Operating Instructions</b> .....	<b>23</b>
Installing Above 2000 Feet.....	6	<b>Cleaning Maintenance</b> .....	<b>25</b>
Orifice Sizes, Pressures and BTUs.....	6	Venting System .....	25
Installation Planning .....	6	Cleaning Glass .....	25
<b>Fireplace and Insert Dimensions</b> .....	<b>7</b>	Pilot and Burner Flames .....	25
<b>General Installation Information</b> .....	<b>8</b>	Firebox Cleaning .....	25
Clearances .....	8	<b>Maintenance</b> .....	<b>26</b>
<b>Installation</b> .....	<b>9</b>	Maintaining Your Heater's Appearance .....	26
Insert Clearances .....	9	Yearly Service Procedure .....	26
Mantel Clearances .....	9	<b>Blower</b> .....	<b>27</b>
Hearth Requirements .....	9	<b>Replacement Parts</b> .....	<b>28</b>
Insert Placement .....	10	<b>Troubleshooting</b> .....	<b>32</b>
Zero-Clearance (Metal) Fireplace Requirements.....	11	<b>Warranty</b> .....	<b>Back Cover</b>
<b>Vent Installation</b> .....	<b>12</b>		
Installation Precautions .....	12		
Vent Requirements .....	13		
Altitude Considerations .....	13		
Manifold Removal.....	14		
Manifold Installation .....	14		
<b>Insert Installation</b>			
Check Gas Type.....	15		
Installing Gas Piping to Insert/Burner System Location .....	15		
<b>Checking Gas Pressure</b> .....	<b>17</b>		
<b>Electrical Installation</b> .....	<b>18</b>		
Electrical Wiring .....	18		
Remote Wall Switch .....	18		

**INSTALLER**

Please leave these instructions with the owner.

**OWNER**

Please retain these instructions for future reference.

**WARNING**

- **Read this owner's manual carefully and completely before trying to assemble, operate, or service this insert.**
- **Any change to this insert or its controls can be dangerous.**
- **Improper installation or use of this insert can cause serious injury or death from fire, burns, explosions, electrical shock and carbon monoxide poisoning.**

This insert is a vented product. This insert must be properly installed by a qualified service person. The glass door must be properly seated and sealed. If this unit is not properly installed by a qualified service person with glass door properly seated and sealed, combustion leakage can occur.

**CARBON MONOXIDE POISONING:** Early signs of carbon monoxide poisoning are similar to the flu with headaches, dizziness and/or nausea. If you have these signs, the insert may not have been installed properly. Get fresh air at once! Have the insert inspected and serviced by a qualified service person. Some people are more affected by carbon monoxide than others. These include pregnant women, people with heart or lung disease or anemia, those under the influence of alcohol, and those at high altitudes.

Propane/LP gas and natural gas are both odorless. An odor-making agent is added to each of these gases. The odor helps you detect a gas leak. However, the odor added to these gases can fade. Gas may be present even though no odor exists.

Make certain you read and understand all warnings. Keep this manual for reference. It is your guide to the safe and proper operation of this insert.

1. This appliance is only for use with the type of gas indicated on the rating plate. This appliance is not convertible for use with other gases unless a certified kit is used.
2. For propane/LP insert, do not place propane/LP supply tank(s) inside any structure. Locate propane/LP supply tank(s) outdoors. To prevent performance problems, do not use propane/LP fuel tank of less than 100 lbs. capacity.
3. If you smell gas
  - shut off gas supply.
  - do not try to light any appliance.
  - do not touch any electrical switch; do not use any phone in your building .
  - immediately call your gas supplier from a neighbor's phone. Follow the gas supplier's instructions.
4. Never install the appliance
  - in a recreational vehicle
  - where curtains, furniture, clothing, or other flammable objects are less than 36" from the front, top, or sides of the insert
  - in high traffic areas
  - in windy or drafty areas
5. This insert reaches high temperatures. Keep children and adults away from hot surfaces to avoid burns or clothing ignition. Insert will remain hot for a time after shutdown. Allow surfaces to cool before touching.
6. Carefully supervise young children when they are in the same room as the appliance.
7. Do not modify this insert under any circumstances. Any parts removed for servicing must be replaced prior to operating insert.
8. Turn insert off and let cool before servicing, installing, or repairing. Only a qualified service person should install, service, or repair the insert. Have burner system inspected annually by a qualified service person.
9. You must keep control compartments, burners, and circulating air passages clean. More frequent cleaning may be needed due to excessive lint and dust from carpeting, bedding material, pet hair, etc. Turn off the gas valve and pilot light before cleaning insert.
10. Have venting system inspected annually by a qualified service person. If needed, have venting system cleaned or repaired. See *Cleaning and Maintenance*, page 26.
11. Keep the area around your insert clear of combustible materials, gasoline, and other flammable vapor and liquids. Do not run insert where these are used or stored. Do not place items such as clothing or other flammable material near the appliance.

*Continued on page 4*

## IMPORTANT SAFETY INFORMATION

Continued from page 3

12. Do not use this insert to cook food or burn paper or other objects.
13. Never place anything on top of insert.
14. Do not use any solid fuels (wood, coal, paper, cardboard, etc.) in this insert. Use only the gas type indicated on rating plate.
15. This appliance, when installed, must be electrically grounded in accordance with local codes or in the absence of local codes, with the *National Electrical Code*, *ANSI/NFPA 70*, or the *Canadian Electrical Code*, *CSA C22.1*.
16. Do not obstruct the flow of combustion and ventilation air in any way. Provide adequate clearances around air openings into the combustion chamber along with adequate accessibility clearance for servicing and proper operation. Trim panels or surrounds shall not seal ventilation openings in the fireplace.
17. Do not use insert if any part has been exposed to or under water. Immediately call a qualified service technician to inspect the appliance and to replace any part of the control system and/or any gas control that has been under water.
18. Do not operate the appliance if any log is broken.
19. **WARNING: Do not operate the appliance with glass door removed. Replacement of the glass should be done by a licensed or qualified service person.**
20. Cutting any sheet-metal parts of the fireplace, in which the gas insert is to be installed, is PROHIBITED.
21. A gas appliance must not be connected to a chimney flue serving a separate solid-fuel burning appliance.
22. If the factory-built fireplace has no gas access hole(s) provided, an access hole of 1.5 inch (37 mm) or less may be drilled through the lower sides or bottom of the firebox in a proper workmanship like manner. This access hole must be plugged with non-combustible insulation after the gas supply line has been installed.
23. The fireplace flue damper can be fully blocked open or removed for installation of the gas fireplace insert.
24. The fireplace and fireplace chimney must be clean and in good working order and constructed of non-combustible materials. The chimney cleanouts must fit properly.
25. Refractory glass doors, screen rails, screen mesh and log grates can be removed from the fireplace before installing the gas fireplace insert.
26. Children and adults should be alerted to the hazards of high surface temperature and should stay away to avoid burns or clothing ignition.
27. **WARNING: Handle glass door with care to avoid striking or scratching it on hard objects. CAUTION: Do not operate appliance with the glass front removed, cracked or broken.**
28. **Installation and repair should be done by a qualified service person. The appliance should be inspected before use and at least annually by a professional service person. More frequent cleaning may be required due to excessive lint from carpeting, bedding material, etc. It is imperative that control compartments, burners, and circulating air passageways of the appliance be kept clean.**
29. **Young children should be carefully supervised when they in the same room as the appliance. Toddlers, young children, and others may be susceptible to accidental contact burns. A physical barrier is recommended if there are at risk individuals in the house. To restrict access to a fireplace or stove, install an adjustable safety gate to keep toddlers, young children, and other at risk individuals out of the room and away from hot surfaces.**

### SAFETY SCREEN INFORMATION:

**WARNING: A barrier (safety screen) designed to reduce the risk of burns from the hot viewing glass is provided with this appliance and shall be installed for the protection of children and other at-risk individuals.**

**IMPORTANT: Safety Screen must be in place when the fireplace is in operation. If the barrier becomes damaged, the barrier shall be replaced with the manufacturer's barrier for this appliance. Any safety screen, guard, or barrier removed for servicing the appliance, must be replaced prior to operating the appliance.**

## PRODUCT SPECIFICATIONS

- This appliance has been certified for use with either natural or propane gas. See appropriate data plates.
- This appliance is not for use with solid fuels.
- The appliance is approved for bedroom or bedsitting room installations.
- The installation must conform with local codes or, in the absence of local codes, with the *National Fuel Gas Code, ANSI Z223.1/NFPA 54*, or the *National Gas and Propane Installation Code, CSA B149.1*.
- This appliance is mobile home approved.
- The appliance must be properly connected to a venting system.

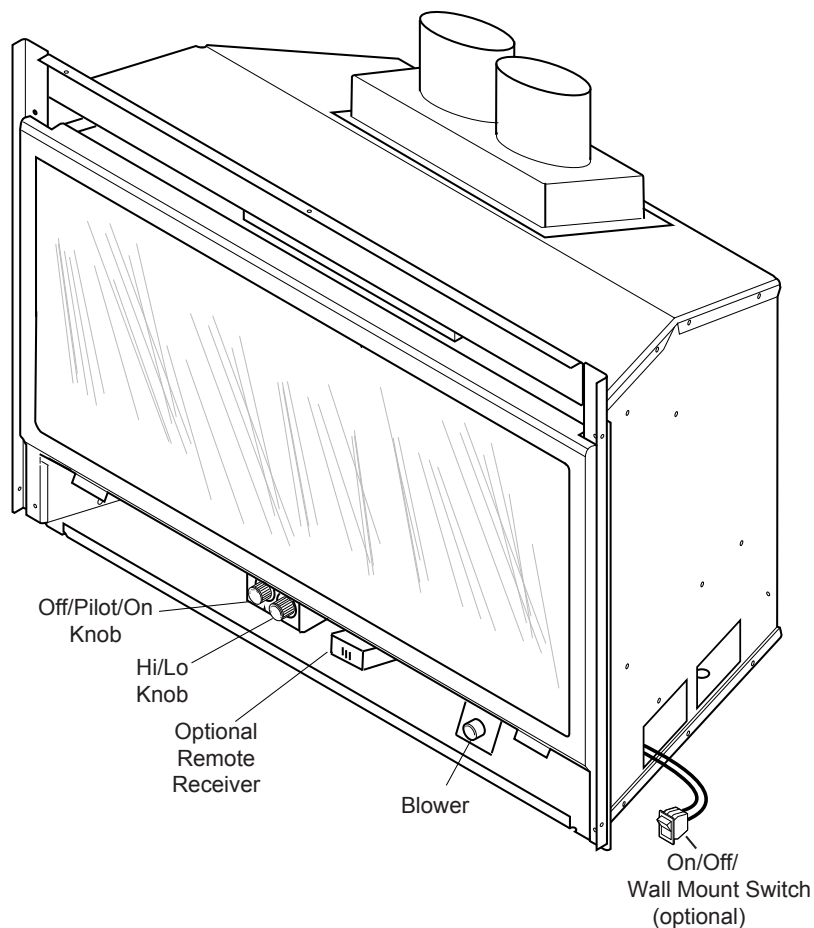

**Figure 1 -DVI751T Insert**

## CODE APPROVAL

Direct Vent type appliances draw all combustion air from outside of the dwelling through the vent pipe.

These appliances have been listed by OMNI and found to comply with the established standards for DIRECT VENT GAS FIREPLACE HEATERS in the USA and Canada as follows:

### LISTED VENTED GAS FIREPLACE HEATER

TESTED TO: ANSI Z21.88-2016/CSA 2.33-2016, CGA 2.17-M91 (R2014), CSA P.4.1-15 STANDARDS

**This appliance may be installed in an aftermarket, permanently located, manufactured home (USA only) or mobile home, where not prohibited by local codes.**

**This appliance is only for use with the type of gas indicated on the rating plate.  
This appliance is not convertible for use with other gases, unless a certified kit is used.**

---

## PRE-INSTALLATION INFORMATION

---

### ATTENTION MASSACHUSETTS RESIDENTS:

This Woodbridge Fireplace Inc. product must be installed by a licensed gas fitter.

### INSTALLING ABOVE 2000 FEET

- In the USA, the appliance must be derated 4% for every 1,000 ft above 2,000 ft elevations.
- In Canada, these appliances are certified for altitudes of 0 – 4500 ft, and must be de-rated an additional 4% for every 1,000 ft. above 4,500 ft. elevations.

### ORIFICE SIZES, PRESSURES AND BTUs

#### NATURAL GAS

Manifold Press: (W.C.)      3.5"  
Maximum Supply Pressure    10.5"  
Minimum Supply Pressure    4.5"

#### PROPANE GAS

Manifold Press: (W.C.)      10"  
Maximum Supply Pressure    13"  
Minimum Supply Pressure    11"

The efficiency rating of this appliance is a product thermal efficiency rating determined under conditions and was determined independently of any installed system.

Thermal Efficiency = up to 80%

Model Number	DVI751T	
	NATURAL	PROPANE
Max. Btu/hr Input	28,500	25,500
Min. Btu/hr Input	18,000	20,000
Orifice sizes	#38	#53

***NOTE: DVI 751 model insert works without any electrical supply.  
Optional blower must have electricity.***

### INSTALLATION PLANNING

Plan for the installation of your insert. This includes determining the size of fireplace in which unit is to be installed, length of venting to be used, and finishing details, and whether any optional accessories (i.e. wall switch, or remote control) are desired. Consult your local building code agency to ensure compliance with local codes, including permits and inspections.

The installer must mechanically attach the marking supplied with the gas fireplace insert to the inside of the fireplace into which the gas fireplace insert is installed.

# FIREPLACE AND INSERT DIMENSIONS

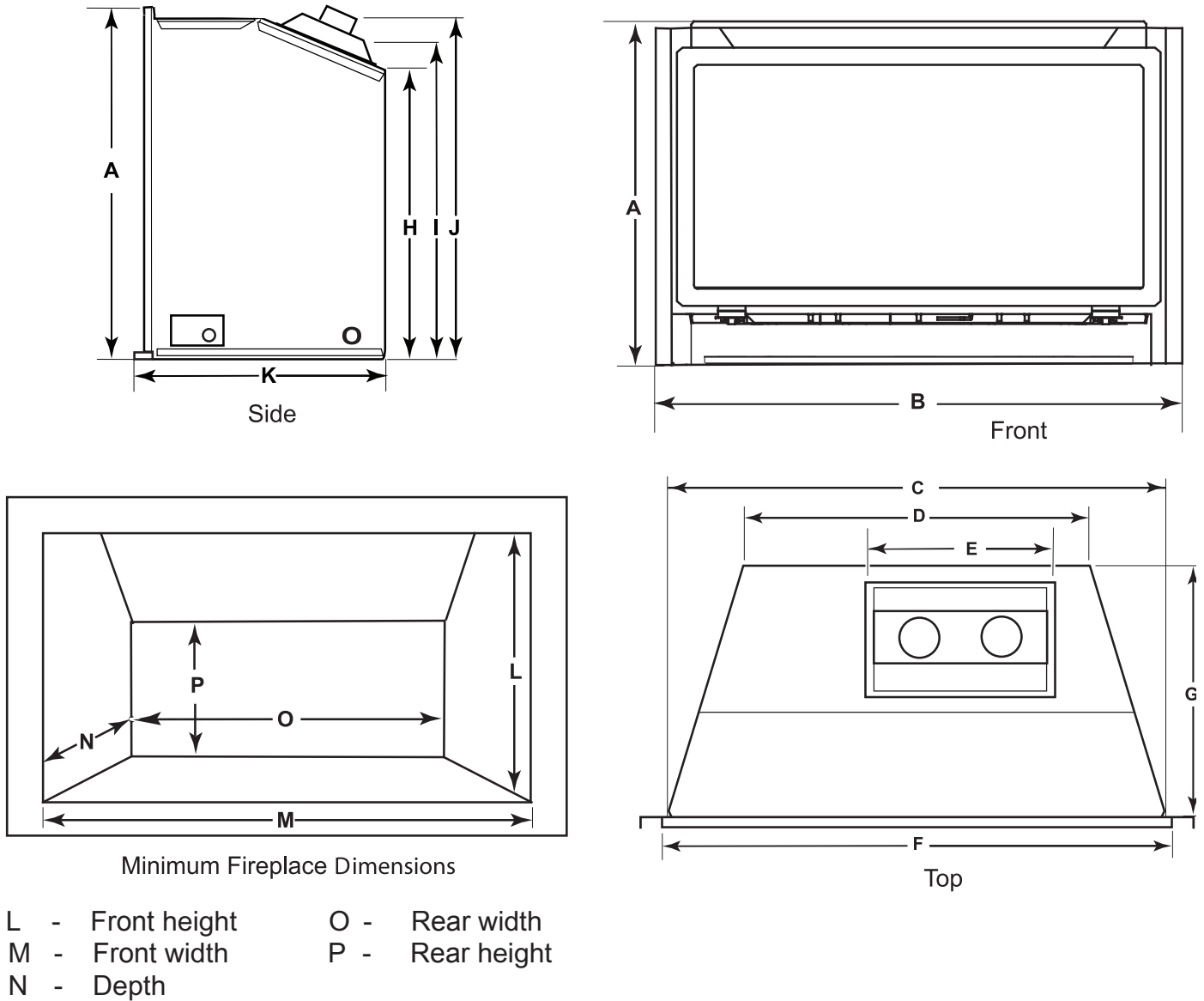

**Figure 2 - Minimum Fireplace and Insert Dimensions**

DIMENSIONS								
DVI 751T			DVI 751T			FIREPLACE		
A	24.75"	629 mm	D	22.00"	559 mm	L	26.0"	660 mm
B	29.75"	756 mm	E	12.00"	305 mm	M	27.0"	686 mm
C	27.25"	692 mm	F	28.75"	730 mm	N	14.0"	356 mm
			G	13.50"	343 mm	O	24.0"	610 mm
			H	19.25"	489 mm	P	23.5"	597 mm
			I	22.75"	578 mm	P	23.5"	597 mm
			J	24.75"	629 mm			
			K	14.25"	362 mm			

---

## GENERAL INSTALLATION INFORMATION

---

The following factors should be taken into consideration:

- This insert should have sufficient access for its safe operation and maintenance.
- The flow of combustion and ventilation air must not be obstructed.
- Minimum clearances to combustibles, such as mantels, **must be maintained**.
- Never obstruct the front opening of the insert.
- Do **not** install in the vicinity where gasoline or other flammable liquids may be stored.
- These units can be installed in a bedroom. See National Fuel Gas Code ANSI Z233.1/NFPA 54 (current edition), the Uniform Mechanical Code (current edition), and Local Building Codes for specific installation requirements.

### INSERT APPLICATIONS

***IMPORTANT: Your direct vent insert is designed to be only vented vertically with a minimum height of 10 feet.***

Before installing the gas fireplace insert, consider the functioning needs of the fireplace. Confirm the size of the fireplace cavity, the design of the chimney, and the availability of the gas supply and electricity for the insert fan.

### MINIMUM FIREPLACE SIZE/CLEARANCES TO COMBUSTIBLES

**IMPORTANT: Your direct vent insert was designed to be installed in an existing wood burning fireplace. The location and clearances are subject to local building codes and the requirements of the gas supplier and NFPA 211.**

When the unit is installed into a woodburning fireplace, the minimum distance the mantel can be placed above the fireplace is governed by local building codes applicable to woodburning fireplaces. Consult local authorities having jurisdiction for these clearances. The underside of the mantel will become warm. Use only finishes which are heat resistant and do not discolor.



**INSERT PLACEMENT**

- Insert must be placed within a code-conforming masonry fireplace or a tested and listed zero-clearance (metal) fireplace. Repair any fireplace damage prior to installation.
- Because the insert uses a circulation blower, clean the fireplace, smoke shelf, and chimney before installing. Paint interior surface of the fireplace with latex paint to further eliminate dust.
- This heater may be placed in a bedroom. Please be aware of the large amount of heat this appliance produces when determining a location.

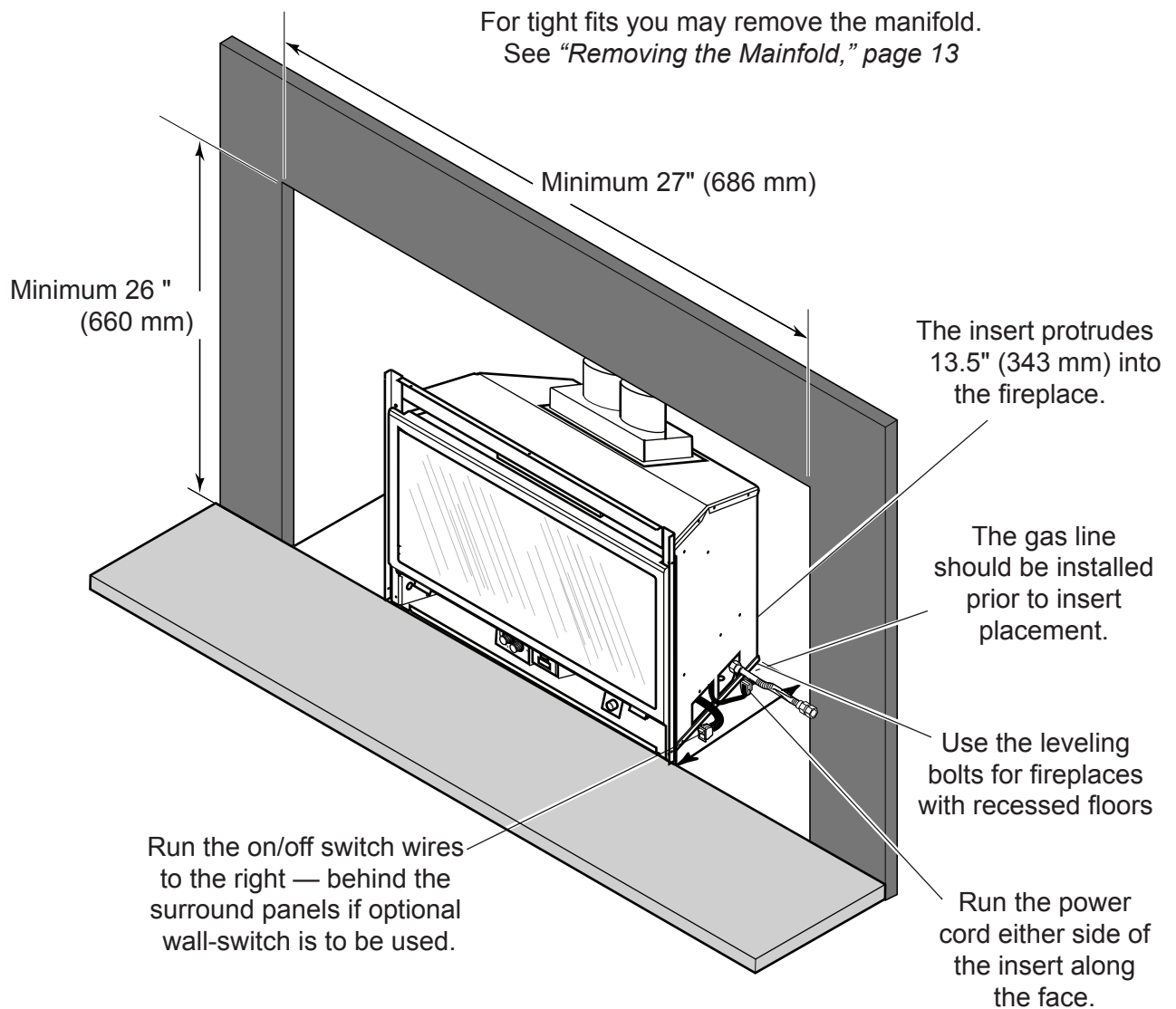

**Figure 3 - Insert Placement**

---

## INSTALLATION

---

### ZERO-CLEARANCE (METAL) FIREPLACE REQUIREMENTS

- The damper and grate must be removed.
- The smoke shelf internal baffles, screen, refractory, and metal or glass doors may be removed (if applicable).

**WARNING**

**Do not cut any sheet metal parts of the fireplace in which this gas fireplace insert is installed. THIS IS STRICTLY PROHIBITED!**

- Do not remove or alter the insulation or any structured rigid frame members (metal sides, floor, door frame, face of the fireplace, etc.).

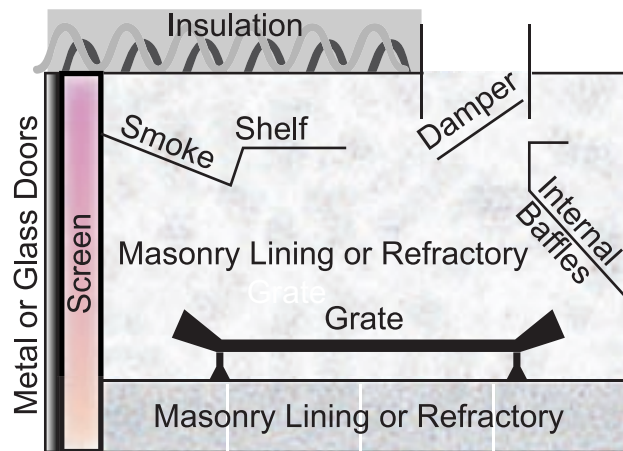

**Figure 5 - Metal Fireplace Zero-Clearance Requirements**

**IMPORTANT:** Please review the following carefully.

It is normal for inserts fabricated of steel to give off some expansion and/or contraction noises during the start up or cool down cycle. Similar noises are found with your furnace heat exchanger or car engine.

It is not unusual for your gas fireplace insert to give off some odor the first time it is burned. This is due to the curing of the paint and any undetected oil from the manufacturing process.

**Please ensure that your room is well-ventilated. OPEN ALL WINDOWS DURING INITIAL BURN OFF/ CURING PHASE.**

Burn your insert for a least six (6) hours on “HIGH” the first time you use it. Place fan in the “OFF” position during this time.

**WARNING**

**Read all instructions completely and thoroughly before attempting installation. Failure to do so could result in serious injury, property damage or loss of life. Operation of improperly installed and maintained venting systems could result in serious injury, property damage or loss of life.**

**NOTICE**

**Failure to follow these instructions will void the warranty.**

### INSTALLATION PRECAUTIONS

Consult local building codes before beginning the installation. The installer must make sure to select the proper vent system for installation. Before installing vent kit, the installer must read this insert manual and vent kit instructions.

Only a qualified installer/service person should install venting system. The installer must follow these safety rules:

- Wear gloves and safety glasses for protection.
- Use extreme caution when using ladders or when on rooftops.
- Be aware of electrical wiring locations in walls and ceilings.

The following actions will void the warranty on your venting system:

- Installation of any damaged venting component.
- Unauthorized modification of the venting system.
- Installation of any component part not manufactured or approved by Woodbridge Fireplace Inc..
- Installation other than permitted by these instructions.

**WARNING**

**This insert must be vented to the outside. The venting system must NEVER be attached to a chimney serving a separate solid fuel burning appliance. Each gas appliance must use a separate vent system. Do not use common vent systems.**

### INSPECTION OF VENT CONNECTION

The vent connection can be inspected at the time of installation by removing the fireplace surround and outer face. See "INSTALLING SURROUND AND OUTER FACE" section of this manual.

# VENT INSTALLATION

## VENT REQUIREMENTS

**WARNING**

- Make sure the exhaust pipe on heater connects to exhaust portion of cap. Attach flex liners. See *Figure 6*.
- Do not crimp or rupture liner when bending it into chimney offsets.

- Vent must meet all vent manufacturer's requirements when installed.
- Make sure you have the following before installing unit:
  - 3" UL 1777 Listed gas liner for air inlet and exhaust (Q-ty: 2 pcs).
  - Vertical termination kit Duravent, Metal-Fab, or SelKirk.

## ALTITUDE CONSIDERATIONS

This heater has been tested at altitudes ranging from sea level up to 4,500 feet (Canada), 0-2000 feet (USA). In this testing, heater with standard orifice burns correctly with just an air shutter adjustment. If you need to resize orifice for use at high altitude, contact your Woodbridge Fireplace dealer.

**WARNING**

Failure to adjust air shutter properly may lead to improper combustion which can create a safety hazard. Consult your dealer or installer if you suspect an improperly adjusted air shutter

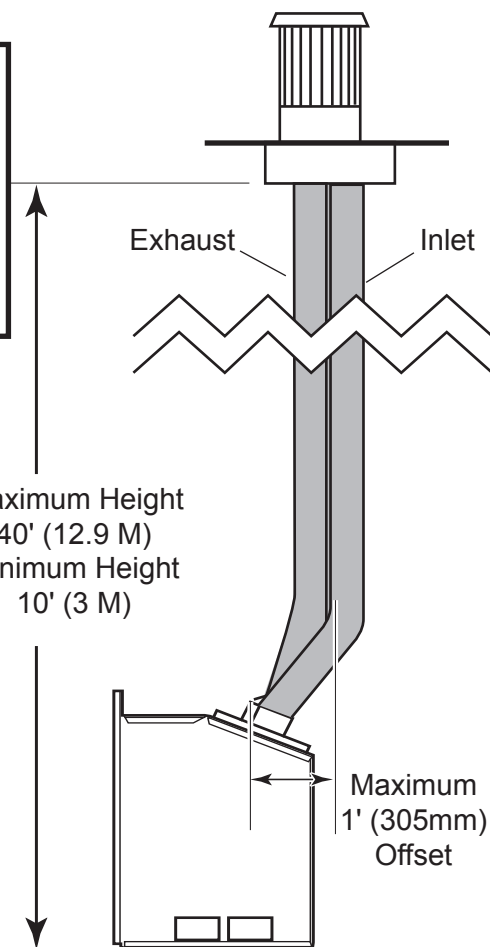

*Figure 5 - Venting Unit*

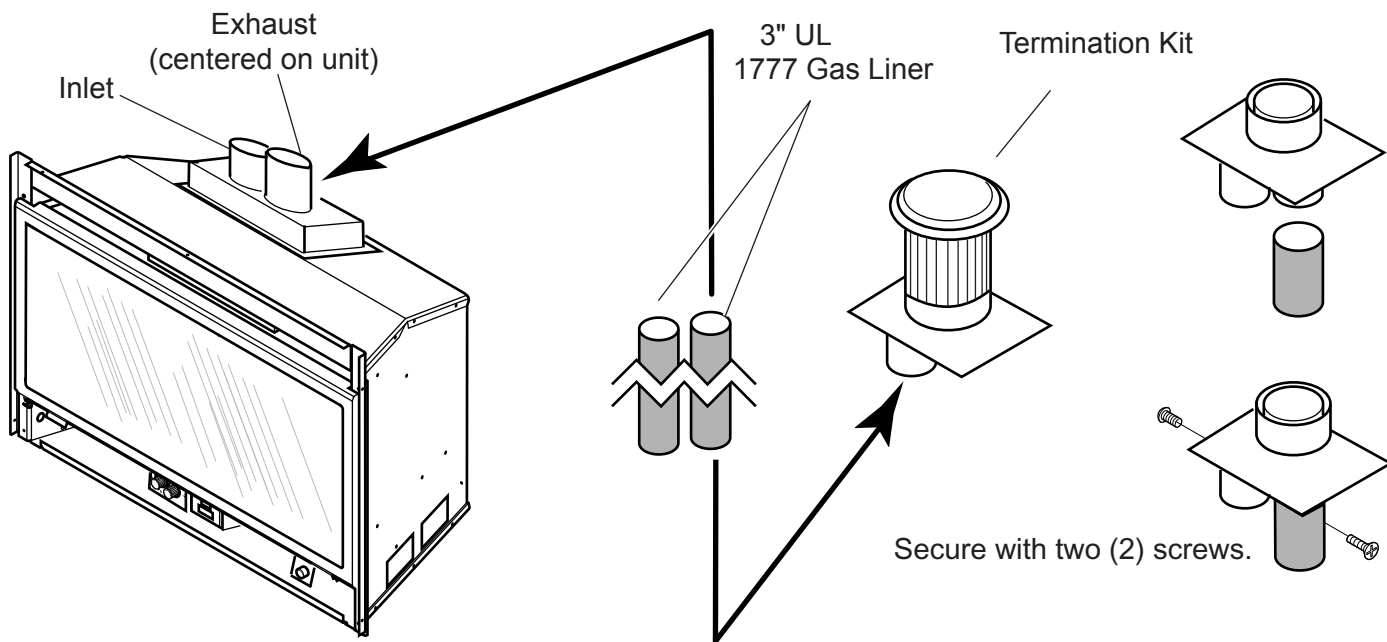

*Figure 6 - Connecting Exhaust Pipe to Heater*

## MANIFOLD REMOVAL AND INSTALLATION

The manifold is shipped attached to insert. It may be removed to allow tight installation. Manifold may be loosened and rotated for desired pipe location.

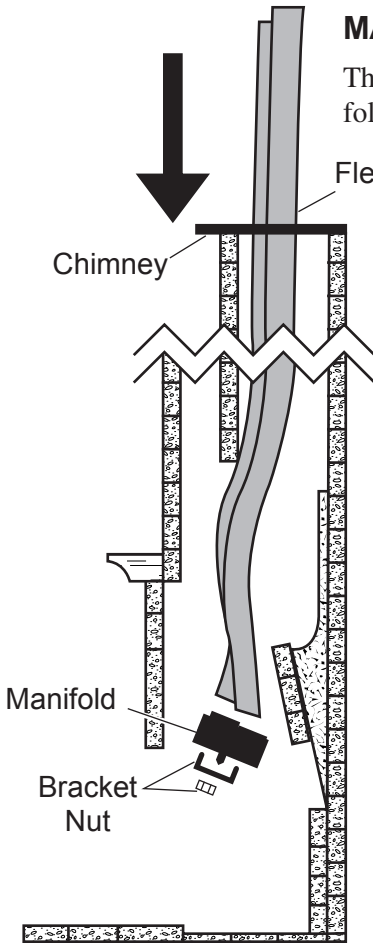

**Figure 7 - Placing Manifold Into Fireplace**

1. Remove brick liner and baffle.
2. Remove manifold. Place manifold in fireplace.
3. Route flex vent through chimney from above. See Figure 7. Leave an extra 3" (914mm) at the top.
4. Attach flex vent to manifold. See Figure 8. Seal with silicone and attach with screws.

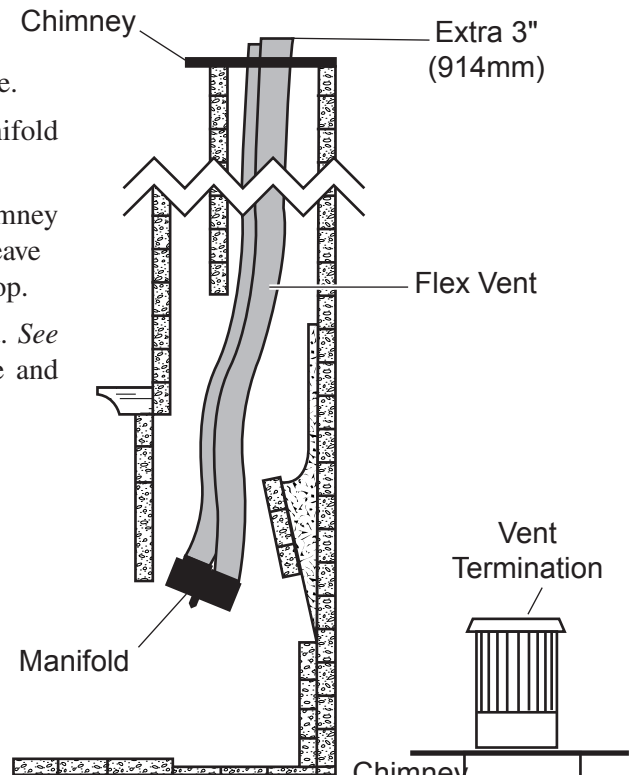

**Figure 8 - Attaching Flex Vent to Manifold**

5. Place manifold in an upright position. Have someone pull on the excess flex vent. Figure 9. Temporarily attach flex vent to top of chimney. Leave some extra slack in flex vent.

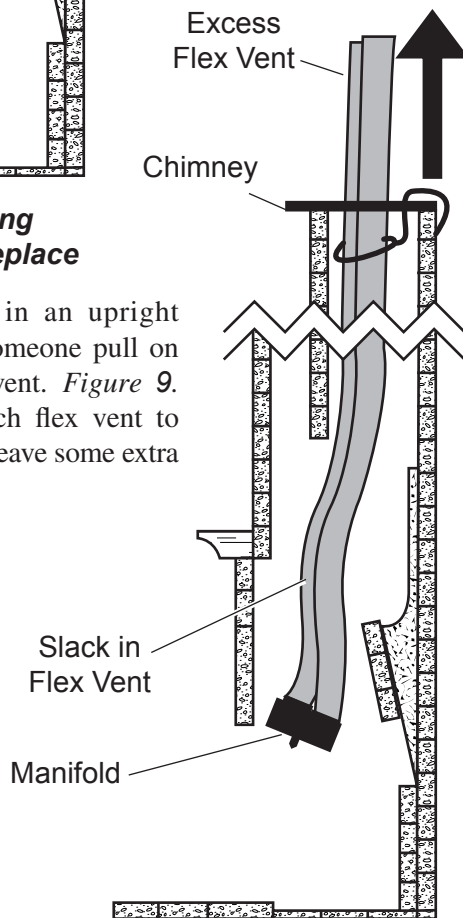

**Figure 9 - Pulling On Excess Flex Vent**

6. Slide insert into place. Guide the manifold over the insert until it is fully in place. Figure 10.
7. Remove any slack from flex vent. Attach manifold to insert. Figure 10.
8. Remove any excess slack in flex line. Attach vent termination. Figure 10.

9. Replace baffle and brick liner.

Excess Slack Taken Out of Flex Vent

Manifold  
Bracket  
Nut  
Insert

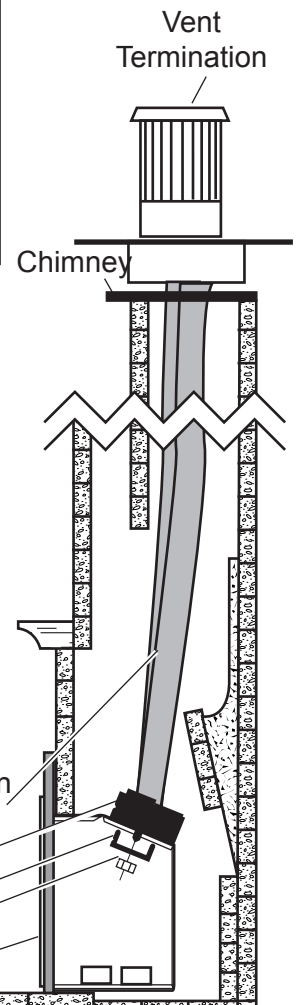

**Figure 10 - Sliding Insert Into Place**

# INSERT INSTALLATION

## CHECK GAS TYPE

Use proper gas type for the insert you are installing. If you have conflicting gas type, do not install insert. See dealer where you purchased the insert for proper insert according to your gas type.

## INSTALLING GAS PIPING TO INSERT LOCATION

**WARNING**

**A qualified installer or service person must connect appliance to gas supply. Follow all local codes.**

**CAUTION**

**For propane/LP units, never connect insert directly to the propane/LP supply. This burner system requires an external regulator (not supplied). Install the external regulator between the burner system and propane/LP supply.**

## INSTALLATION ITEMS NEEDED

Before installing insert and burner system, make sure you have the items listed below.

- External regulator (supplied by installer)
- Piping (check local codes)
- Sealant (resistant to propane/LP gas)
- Test gauge connection\*
- Sediment trap (optional but recommended)
- Tee joint
- Pipe wrench
- approved flexible gas line with gas connector (if allowed by local codes — not provided)

\* A CSA design-certified equipment shutoff valve with  $\frac{1}{8}$ " NPT tap is an acceptable alternative to test gauge connection. Purchase the CSA design-certified equipment shutoff valve from your dealer.

For propane/LP connections only, the installer must supply an external regulator. The external regulator will reduce incoming gas pressure. You must reduce incoming gas pressure to between 11 and 13 inches of water. If you do not reduce incoming gas pressure, burner system regulator damage could occur. Install external regulator with the vent pointing down as shown in *Figure 11*. Pointing the vent down protects it from freezing rain or sleet.

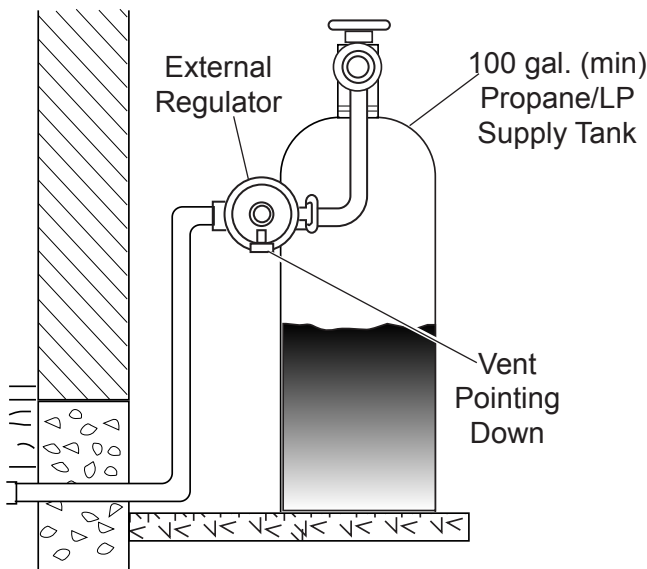

**Figure 11 - External Regulator with Vent Pointing Down (Propane/LP Only)**

**CAUTION**

**Use only new black iron or steel pipe. Internally tinned copper or copper tubing can be used per National Fuel Code, section 2.6.3, providing gas meets hydrogen sulfide limits, and where permitted by local codes. Gas piping system must be sized to provide minimum inlet pressure (listed on data plate) at the maximum flow rate (BTU/hr). Undue pressure loss will occur if the pipe is too small.**

When using copper or flex connectors use only fittings approved for gas connections. The gas control inlet is  $\frac{3}{8}$ " NPT.

**WARNING**

Only persons licensed to work with gas piping may make the necessary gas connections to this appliance.

**CAUTION**

A manual shutoff valve is factory installed upstream of the appliance. Union tee and plugged  $\frac{1}{8}$ " NPT pressure tapping point should be installed upstream of the appliance. See Figure 12.

**NOTE :** The gas line connection may be made using  $\frac{1}{2}$ " rigid tubing or an approved flex connector. Since some municipalities have additional local codes it is always best to consult your local authorities and the current edition of the National Fuel Gas Code ANSI.Z223.1, NFPA54. In Canada CAN/CGA-B149 (1 or 2) Installation Code.

A listed manual shutoff is factory installed upstream of appliance. Union tee and plugged  $\frac{1}{8}$ " NPT pressure tapping point should be installed upstream of the appliance. See Figure 12.

**IMPORTANT:** The main gas valve is for turning on or shutting off the gas to the insert.

Check your building codes for any special requirements for locating equipment shutoff valve to inserts.

Apply pipe joint sealant lightly to threads. This will prevent excess sealant from going into pipe. Excess sealant in pipe could result in clogged burner system valves.

**CAUTION**

Use pipe joint sealant that is resistant to liquid petroleum (LP) gas.

We recommend that you install a sediment trap/drip leg in supply line as shown in Figure 12. Locate sediment trap/drip leg where it is within reach for cleaning. Install in piping system between fuel supply and burner system. Locate sediment trap/drip leg where trapped matter is not likely to freeze. A sediment trap traps moisture and contaminants. This keeps them from going into the burner system gas controls. If sediment trap/drip leg is not installed or is installed wrong, burner system may not run properly.

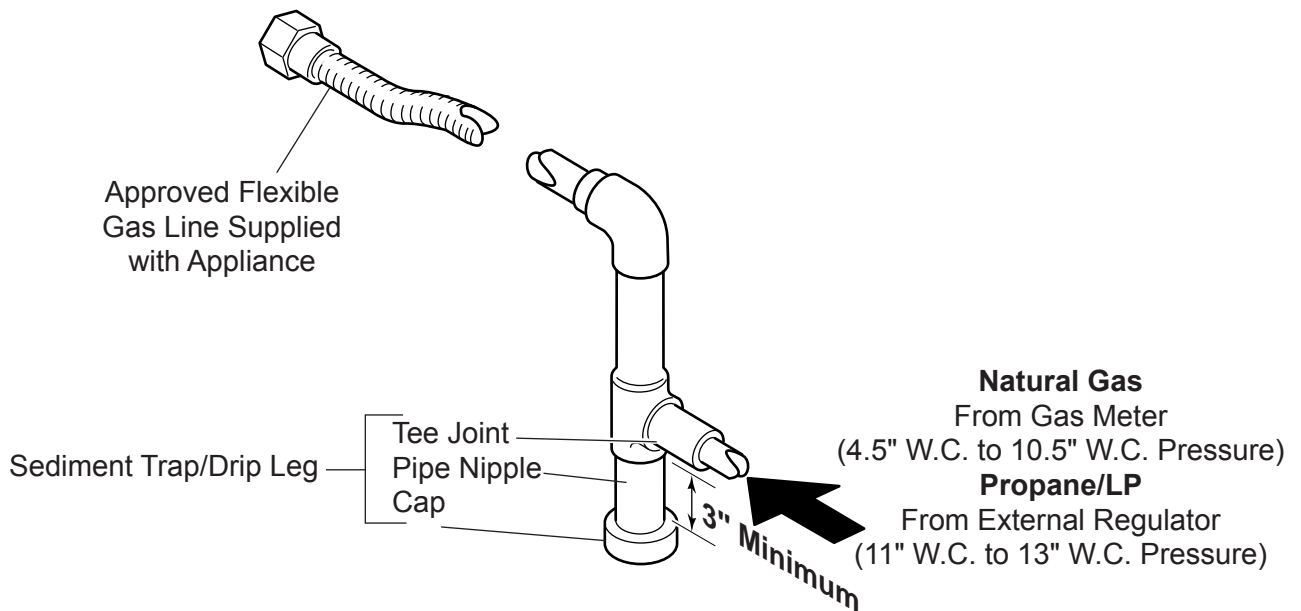
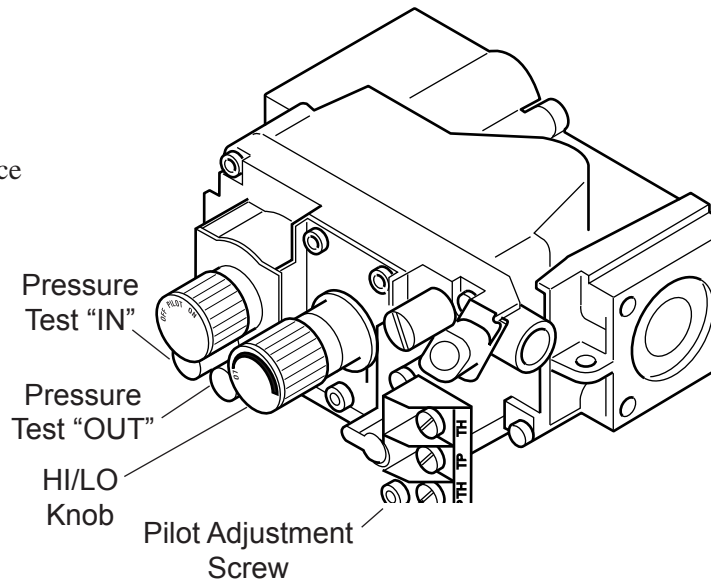

Figure 12 - Gas Connection

## CHECKING GAS PRESSURE

1. Check gas type. The gas supply must be the same as stated on the appliance's rating decal. If the gas supply is different from the fireplace, STOP! Do not install the appliance. Contact your dealer immediately.
2. Install and attach c flex line provided by this appliance to  $\frac{1}{2}$ " gas line.
3. After completing gas line connection, purge air from gas line and test all gas joints from the gas meter to the fireplace for leaks. Use a soap and water solution or a gas sniffer.
4. To adjust flame height, turn HI/LO knob to HI to get maximum pressure to burner. Turn HI/LO knob to LO to get minimum pressure.
5. To check gas pressures at valve, turn captured screw counter clockwise 2 or 3 turns and then place tubing to pressure gauge over test point. Turn unit to high. *See Figure 13.* After taking pressure reading, be sure and turn captured screw clockwise firmly to reseal. Do not over torque. Check test points for gas leaks with a soap and water solution.
6. The appliance and its appliance main gas valve must be disconnected from the gas supply piping system during any pressure testing of that system at test pressures in excess of  $\frac{1}{2}$  psi (3.5 kPa). The appliance must be isolated from the gas supply piping system by closing its equipment shutoff valve during any pressure testing of the gas supply piping system at test pressures equal to or less than  $\frac{1}{2}$  psi.



**Figure 13 - Gas Pressure Check at Gas Valve**

### WARNING

**Do not use open flame to check for gas leaks.**



**ELECTRICAL WIRING**

This insert will work without any electrical supply. Electricity is only needed to operate blower.

**WARNING**

Electrical connections should only be performed by a qualified, licensed electrician. Main power must be off when connecting to main electrical power supply or performing service. All wiring shall be in compliance with all local, city, and state codes. The appliance, when installed, must be electrically grounded in accordance with local codes, or in the absence of local codes, with the *National Electrical Code ANSI/ NFPA 70 (latest edition)* and *Canadian Electrical Code, CSA C22.1*.

**CAUTION**

Label all wires before disconnecting when servicing controls. Wiring errors can cause improper and dangerous operation.

Verify proper operation after servicing.

**REMOTE WALL MOUNTED SWITCH**

A remote wall switch and up to fifteen (15) feet of 18 Ga. wire may be used with this appliance. Attach the wall switch in a junction box at the desired location on the wall. *See Figure 15.*

**NOTE:** Extended lengths of wire may cause the fireplace not to function properly. Longer length of wire is permitted if the wire is made out of larger gauge (diameter) wire. Always check with local code.

**DANGER!** THE WALL SWITCH OR WALL THERMOSTAT MUST **NEVER** BE CONNECTED TO ANY EXTERNAL POWER SUCH AS HOUSEHOLD 110V CIRCUIT!

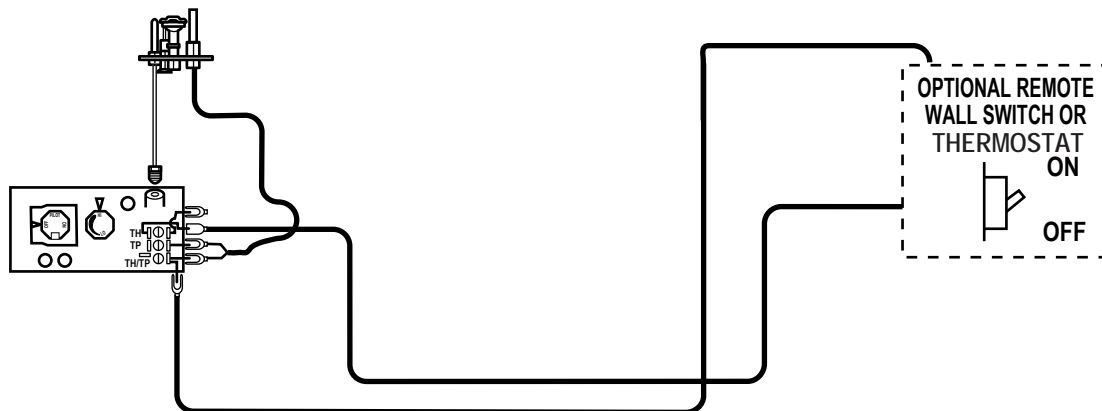

*Figure 15 - Wiring Diagram for Wall Switch*

---

## GLASS MEDIA AND OPTIONAL STONE PLACEMENT

---

### WARNING

The positioning of the optional stones is critical to the safe and clean operation of this heater. Sooting and other problems may result if the stones are not properly positioned in the appliance. Never add additional stones or embellishments such as pine cones or vermiculite to the heater. Only use the stones supplied with the unit. Failure to position the parts in accordance with diagrams below or to use only parts specifically approved for this heater may result in property damage or personal injury.

### WARNING

Do not operate the appliance without the burner being completely filled with glass media. Lighting the burner without the glass media will cause unsafe temperatures within the appliance.

#### GLASS MEDIA PLACEMENT IN THE FIREBOX

1. Open front door of firebox.
2. If optional stones are not provided, cover entire burner and surrounding area with supplied glass media as shown. Avoid blocking pilot area with excess of media.



### WARNING

Do not use the entire bag of glass media to cover the burner. This could cause the flame to burn poorly and may lead to sooting.

### INSTALLING OPTIONAL STONES AND GLASS MEDIA IN THE FIREBOX

1. Remove the glass door from the firebox.
2. Place the first five stones (the smallest in size) as shown below.

*IMPORTANT: Avoid ports when placing stones on the burner.*



3. Cover entire burner around the stones as well as surrounding area with the supplied glass media.

*IMPORTANT: Avoid blocking pilot area with excess of media.*



---

## STONE PLACEMENT *(continued)*

---

- Set eight (8) larger stones along the burner surround as shown.



**NOTE:** Use only original Woodbridge Fireplace replacement parts.

**CAUTION**

Always use gloves when handling broken glass.

**WARNING**

Make sure the glass panel edges do not touch any metal parts during thermal expansion.

1. Remove three nuts, washers and springs.

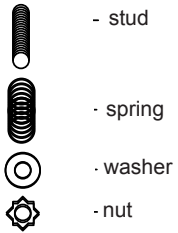

2. Carefully remove the glass door. See Figure 16.
3. Install the replacement glass door (Part # A100136).

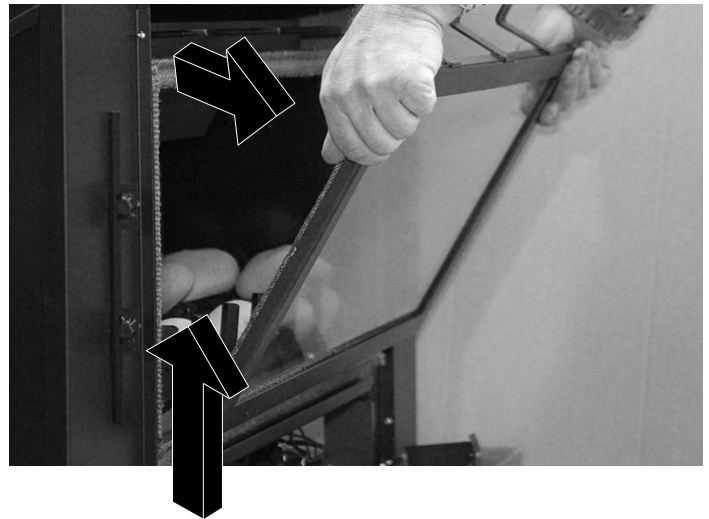

**Figure 16 - Removing Glass Door**

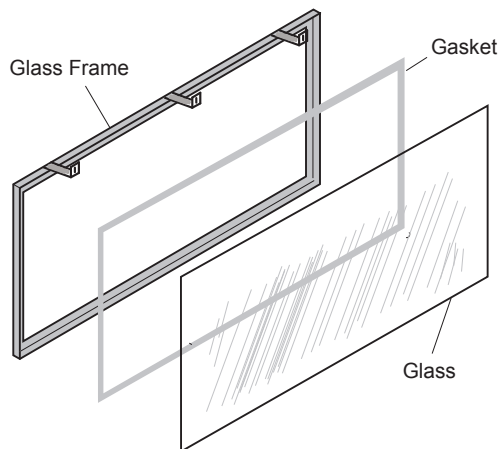

**Figure 17 - Glass Door Assembly**



4. Replace the springs, washers, and nuts as shown. Tighten the nuts until they are flush with the end of the studs. Do NOT over tighten.

---

## INSTALLING SURROUND AND OUTER FACE

---

1. Fasten the surround to the firebox using 4 screws provided ( two on each side).

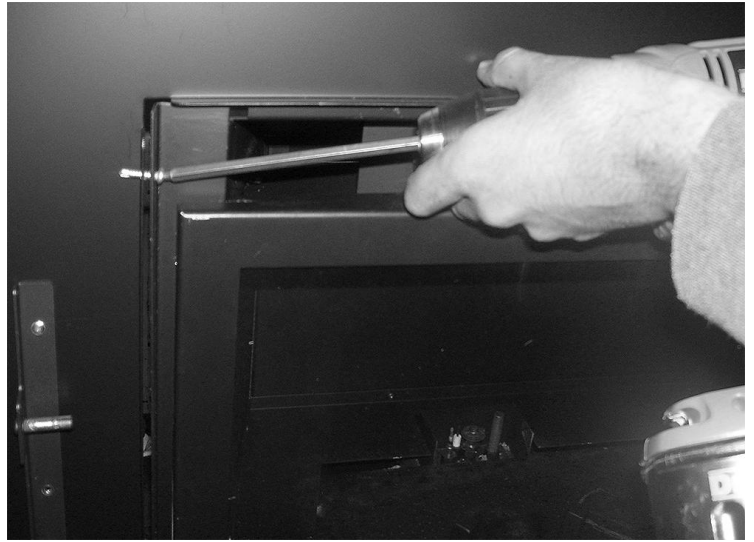

### NOTICE

Before installing the facing remove all fingerprints from the glass door and facing with a 50/50 vinegar and water solution. Any fingerprints left on the glass or the facing will be permanent when heater is lit.

2. Locate the vertical hooks on both sides at the back of the outer face.
3. Place the outer face in front of the appliance and align the hooks with the horizontal pins.
4. Position the outer face so the hooks are going over the horizontal pins and then allow the face to drop down firmly inside the slots.



*Figure 18 - Installing Outer Face*

**FOR YOUR SAFETY  
READ BEFORE LIGHTING**

**WARNING:** If you do not follow these instructions exactly, a fire or explosion may result causing property damage, personal injury, or loss of life.

- A. This appliance has a pilot which must be lit manually. When lighting the pilot, follow these instructions exactly.
- B. **BEFORE LIGHTING** smell all around the appliance area for gas. Be sure to smell next to the floor because some gas is heavier than air and will settle on the floor.



**WHAT TO DO IF YOU SMELL GAS**

1. Do not try to light any appliance.
  2. Do not touch any electric switch.
  3. Do not use any phone in your building.
  4. Immediately call your gas supplier from a neighbor's phone. Follow the gas supplier's instructions.
  5. If you cannot reach your gas supplier, call the fire department.
- C. Use only your hand to push in or turn the gas control knob. Never use tools. If the knob will not push in or turn by hand, do not try to repair it, call a qualified service technician. Force or attempted repair may result in a fire or explosion.
- D. Do not use this appliance if any part has been under water. Immediately call a qualified service technician to inspect the appliance and to replace any part of the control system and any gas control which has been under water.

**TO TURN OFF GAS  
TO APPLIANCE**

1. Turn off wall switch or thermostat. Turn off all electric power to the appliance if service to be performed.
  2. Open access panel.
  3. Push in gas control knob slightly and turn clockwise to "OFF". Do not force.
-  to "OFF". Do not force.
4. Replace access panel.

## LIGHTING INSTRUCTIONS

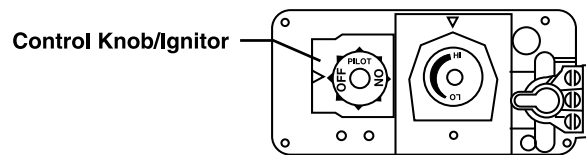

1. **STOP! Read "For Your Safety" information first before lighting (see to the left).**
2. Turn off all electric power to the appliance.
3. Turn ON/OFF switch to "OFF" position or set thermostat to lowest setting.
4. Turn manual shutoff valve counterclockwise  to OPEN position.
5. Open access panel.
6. Push in gas control knob slightly and turn clockwise  to "OFF" position. Do not force.

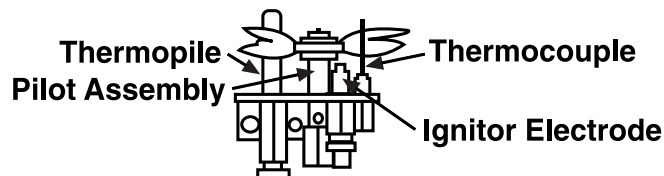

7. Wait five (5) minutes to clear out any gas. Then smell for gas, including near the floor. If you smell gas **STOP! Follow "WHAT TO DO IF YOU SMELL GAS" in "FOR YOUR SAFETY..." (see to the left).** If you don't smell gas, go to the next step.
8. Remove glass door before lighting (see "Glass Door Removal" in manual).
9. Visually locate pilot assembly by main burner.
10. Turn knob on gas control counterclockwise  to "PILOT" position.
11. Push in control knob all the way and hold in until a flame appears at pilot assembly. If flame does not appear after several attempts, repeat steps 6 to 10.



If flame appears, hold control knob in for about one (1) minute. Release knob and it will pop back into original position. Pilot should remain lit. If it goes out, repeat Steps 6 to 10.

- If knob does not pop up when released, stop and immediately call your service technician or gas supplier.
  - If the pilot will not stay lit after several attempts, turn the gas control knob clockwise  to "OFF" and call your service technician or gas supplier.
12. Reinstall glass door.
  13. Turn gas control knob counterclockwise  to "ON" position.
  14. Turn on all electric power to the appliance. Close access panel.
  15. Turn the ON/OFF switch to "ON" position or set thermostat to desired setting.



Make sure the gas valve knob is in the “OFF” position. Wait at least five (5) minutes before starting maintenance.

### VENTING SYSTEM

A qualified agency should examine the venting system annually.

### CLEANING GLASS

Clean the ceramic glass periodically. Condensation will sometimes form on the glass during a cold startup. This is normal for all gas fireplaces and inserts. This condensation often attracts dust and lint to the surface of the glass. The initial paint curing of the appliance can also leave a slight film on the glass. This is a temporary problem. You should clean the glass after the first two weeks of use. After that, you should clean the glass no more than two or three times a season. Use a mild glass cleaner to clean the door.

**WARNING: Do not use abrasive cleaners. They will damage the glass surface.**

### PILOT AND BURNER FLAMES

Visually check pilot and burner flame periodically. See Figure 27 for typical burner flame. There is no air adjustment on the main burner. The air shutter is preset at the factory. See Figure 28 for typical pilot flame.



Figure 19- Typical Burner Flame

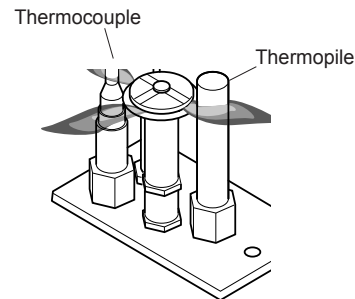

Figure 20 - Typical Pilot Flame

### AIR SHUTTER ASSEMBLY

Air shutter is adjusted at factory:  $\frac{3}{16}$ " for natural gas and fully open with two additional  $\frac{3}{8}$ " dia. holes for propane gas. If necessary, change this by loosening nut and opening or closing the air shutter more.

### FIREBOX CLEANING

1. Carefully remove log set, and embers from combustion chamber.
2. Vacuum burner compartment thoroughly.
3. Vacuum any dust off logs.
4. Remove any lint from main burner and pilot.
5. Carefully replace log set, and embers in their correct positions. *See pages 18 through 21.*
6. Replace door (if it has been removed).
7. Relight pilot. *See page 25.*
8. Turn on main burners.

**WARNING**

**Any parts that need to be replaced must be ordered from the manufacturer. Do not use substitute materials.**

**WARNING**

**Make sure that clearances to combustibles leave enough room for maintenance and service.**

**WARNING**

**Carefully reassemble and reseal insert properly after any cleaning or servicing.**

## MAINTENANCE

### MAINTAINING YOUR HEATER'S APPEARANCE

Fingerprints or other marks left on optional gold or nickel surface may become etched in place if they are not wiped clean prior to turning stove on. Clean gold or nickel with a 50/50 vinegar and water solution and soft cloth soft cloth.

**NOTE: Make sure heater is cool before cleaning. Using cleaners other than a 50/50 vinegar and water solution may leave a film that becomes permanently etched into the gold or nickel.**

### YEARLY SERVICE PROCEDURE

Failure to inspect and maintain heater may lead to improper combustion and a potentially dangerous situation. A qualified technician should do the following once a year.

1. Check pilot flame. Flame should touch approximately  $\frac{3}{8}$ " of the top of thermopile and touch top of thermocouple. *See Figure 21.* If not, contact dealer for service.
2. Turn gas control knob to "OFF" position to shut off gas to heater. *See step "To Turn Off Gas", page 23.* Let heater cool for 15 minutes. Remove outer face and glass door. *See pages 21, 22.*
3. Carefully remove stone set. If stones are severely deteriorated, replace stones. Check stones for sooting. A small amount of soot along bottom of stones is normal. If excessive sooting is found, heater must be adjusted. Contact dealer where you bought heater.
4. Clean burner and burner ports. Inspect the following. *See Figure 22:*
  - Check burner ports for cracks, warpage and corrosion.
  - Make sure burner assembly is not warped or damaged.
  - Check firebox and area around pilot to make sure there is no warping or damage.

If any problem is found, do not use heater. Contact your dealer for service.

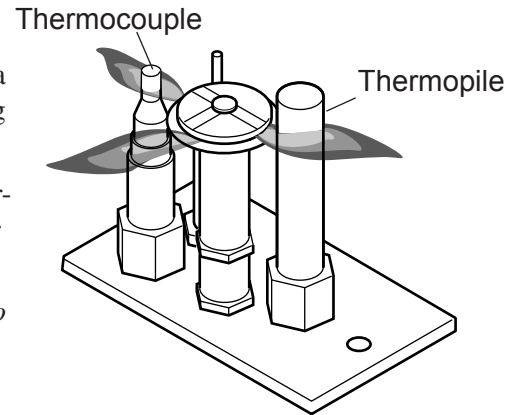

**Figure 21 - Before taking unit apart, check pilot flame. Flame should touch thermocouple and thermopile**

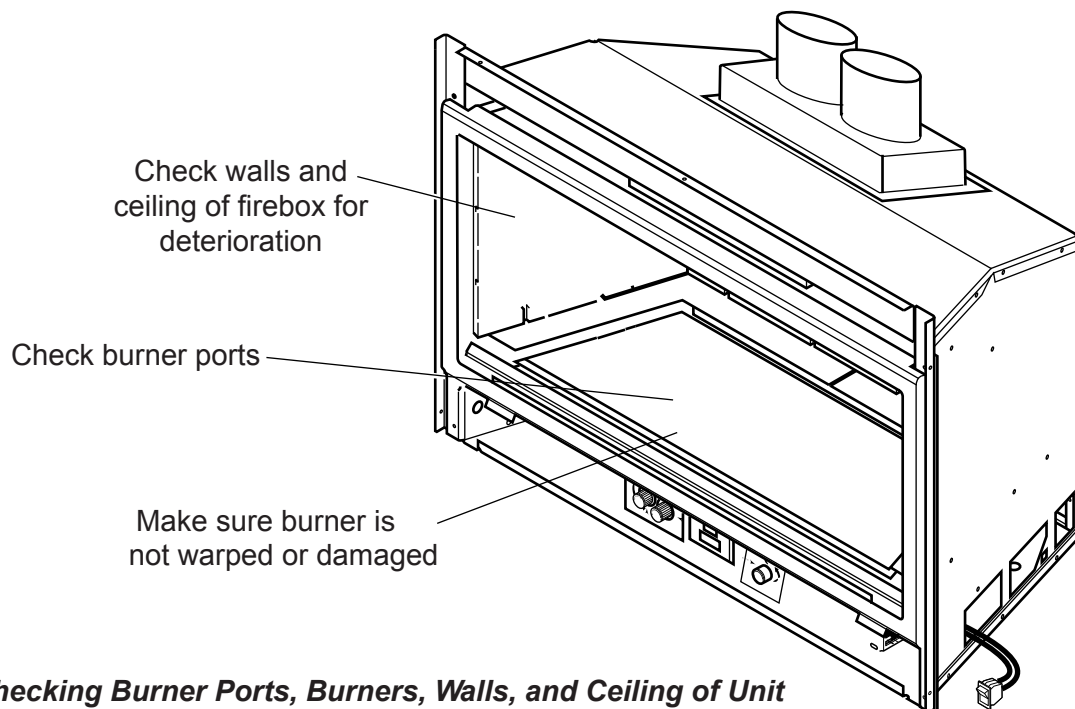

**Figure 22 - Checking Burner Ports, Burners, Walls, and Ceiling of Unit**



*Continued on Next Page*

- Replace stone set and glass media per instructions on pages 18-20. Replace glass. Make sure gasket along perimeter of glass contacts face of firebox and forms an airtight seal. Realign if airtight seal is not formed. Replace glass and glass frame if damaged.
- Inspect area behind access door. Clean if necessary. Check gas control valve and all gas lines. If damaged, do not use heater. Contact your dealer.
- Start pilot and turn on main burner. Flames should be orange/yellow and not touch top of firebox. If pilot or main burner do not burn correctly, contact your dealer for service. Monitor blower operation.

## BLOWER

### ADJUSTING BLOWER SPEED

The internal blower helps transfer heat from heater into room. It will not turn on until heater is up to temperature (approximately 10 minutes after starting).

To turn blower off, turn knob all the way counterclockwise . One click clockwise turns blower to high speed. Turning knob clockwise  from high position decreases speed of blower.

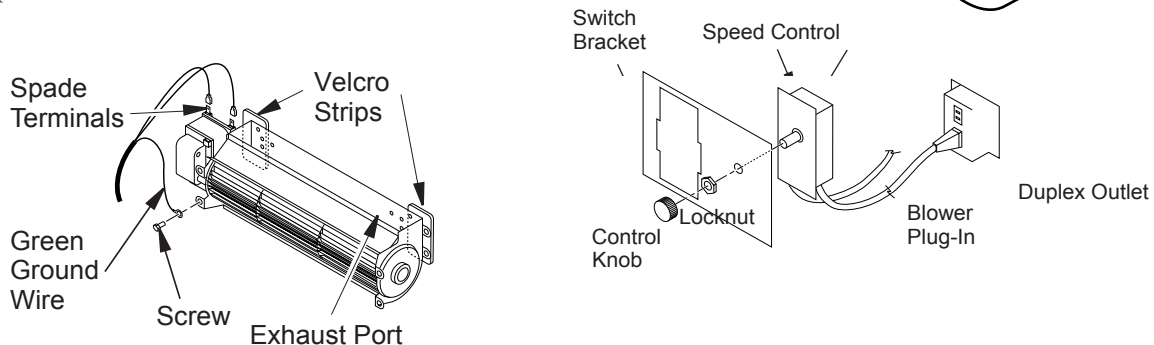
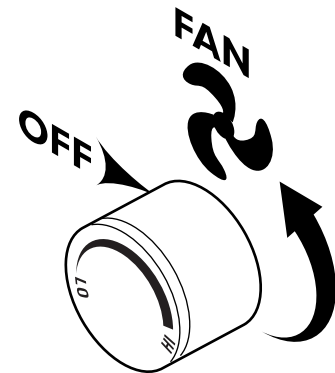

**NOTE:** *Unplug power cord before servicing. The blower is attached to the insert bottom and back with Velcro. To remove blower for servicing, pull away from Velcro and disconnect wires.*

**CAUTION:** Label all wires prior to disconnection when servicing controls. Wiring errors can cause improper and dangerous operation. Verify proper operation after servicing.

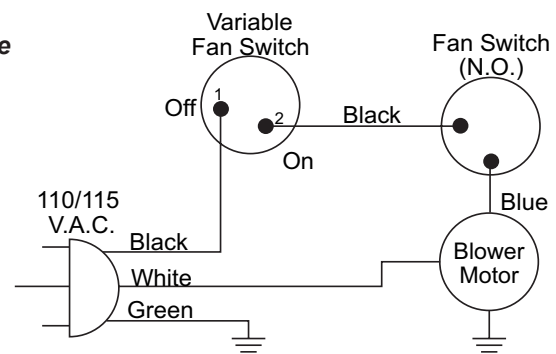
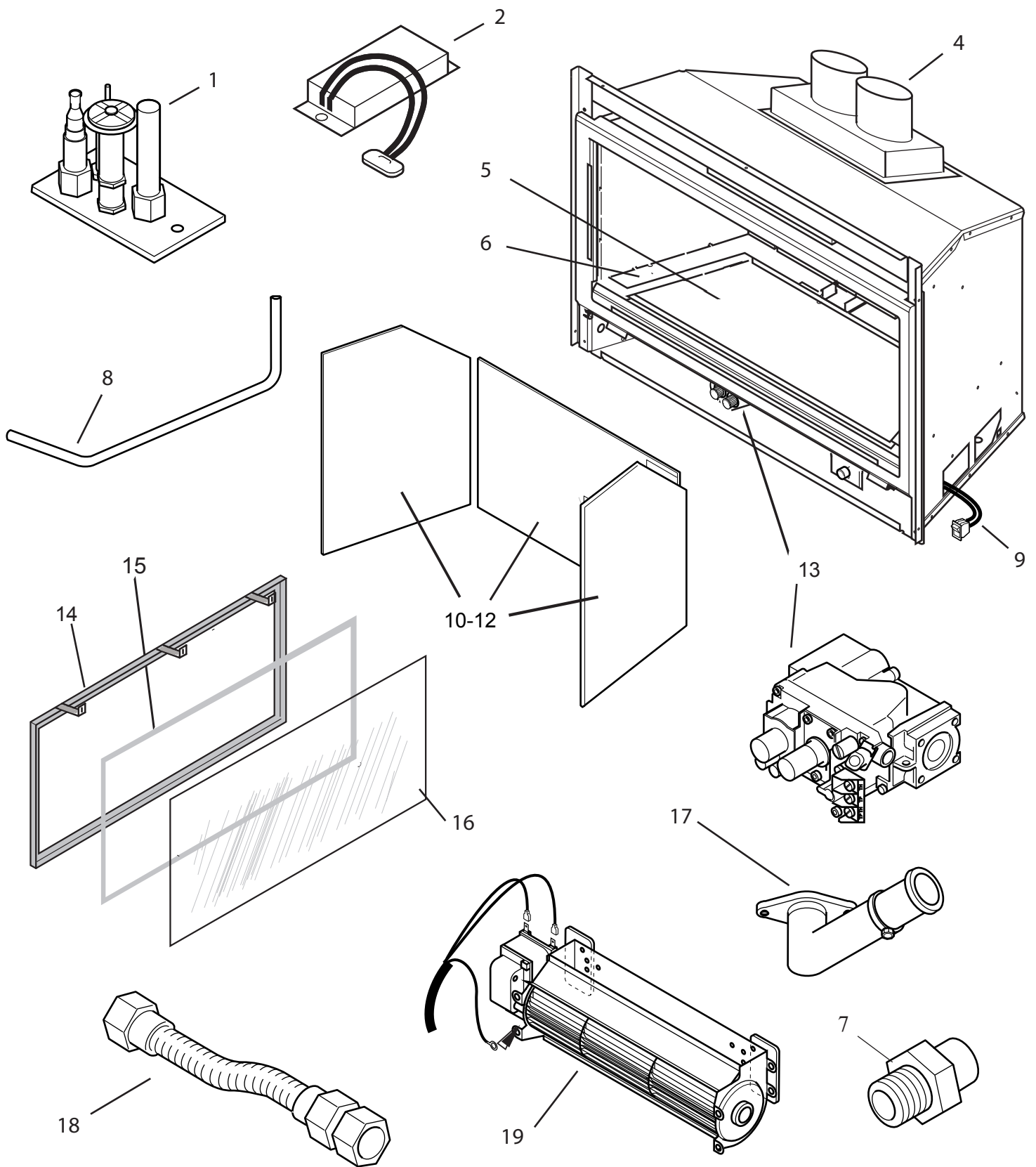

Figure 23 - Fan wire assembly diagram

### WARNING Electrical Grounding Instructions

The appliance is equipped with a three-prong (grounding) plug for your protection against shock hazard and should be plugged into a properly grounded three-prong receptacle. Do not cut or remove the grounding prong from this plug.

# REPLACEMENT PARTS



Continued on Next Page

DVI 751 13 pcs Optional Stone Set ( Part Number G100007):

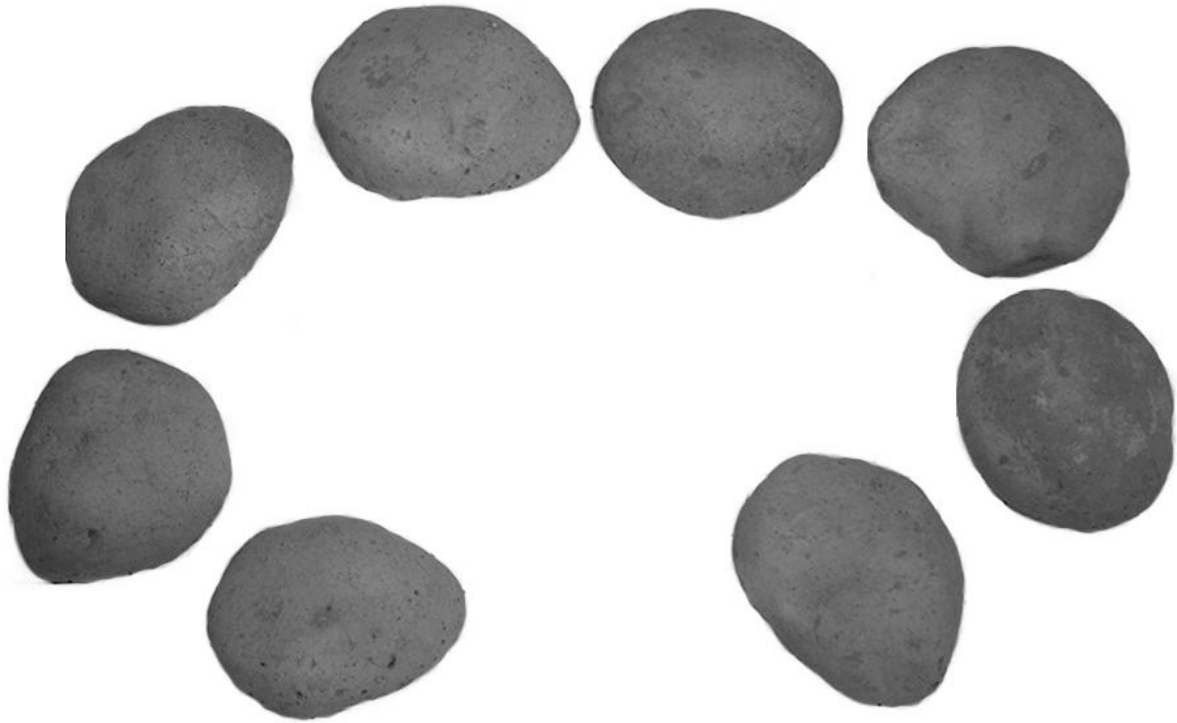

Back Row Larger Stones



Front Row Smaller Stones

*Continued on Next Page*

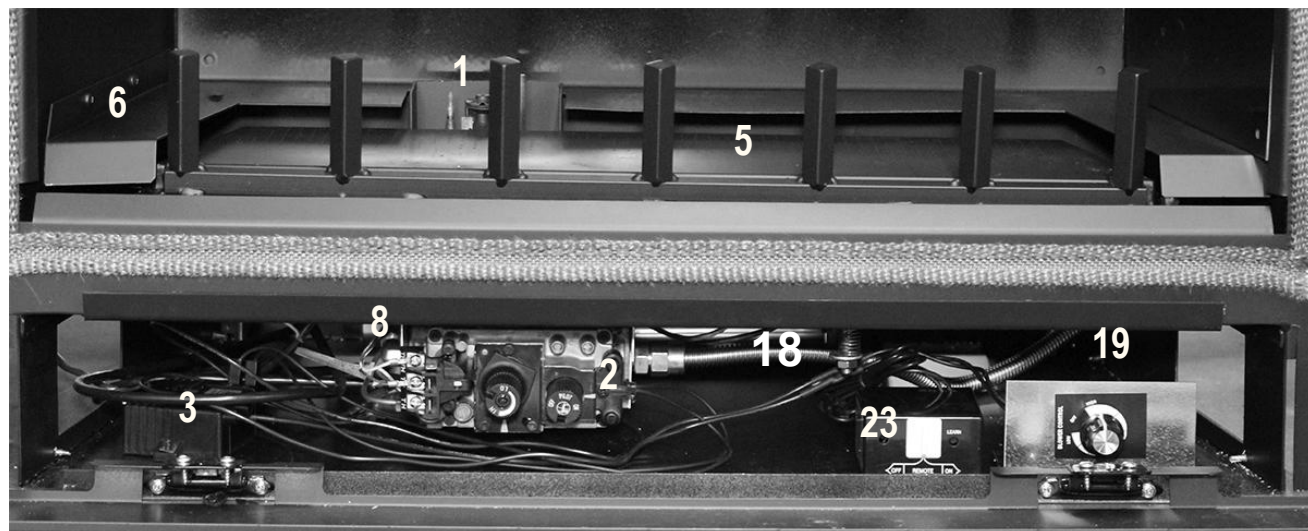

20



## REPLACEMENT PARTS

This list contains replaceable parts used in your firebox.

All replacement parts should be ordered from your installer or from Woodbridge Fireplace Inc.  
at 1-905-564-3001 or on-line at [www.woodbridgedealer.com](http://www.woodbridgedealer.com)

Item	Description	QTY	DVI 751T	
			Natural	Propane
1	SIT Pilot Assembly	1	C100003	C100004
2	Ignition Switch w/cable	1	C100013	C100013
3	Battery Igniter	1	C100012	C100012
4	Vent Manifold	1	W100100P	W100100P
5	Burner Weldment	1	W500025P	W500023P
6	Log Support	1	E200020P	E200020P
7	Orifice	1	E100111	E100112
8	Burner Tube	1	C100037	C100037
9	Optional Wall Switch	1	A100000	A100000
10	Left Reflective Panel	1	E300134L	E300134L
11	Rear Reflective Panel	1	E300133	E300133
12	Right Reflective Panel	1	E300134R	E300134R
13	Main Gas Valve	1	C100001	C100002
14	Glass Frame*	1	W200127P	W200127P
15	Glass Frame Gasket*	1	I100015	I100015
16	Ceramic Glass*	1	G100108	G100108
17	Venturi	1	C100008	C100008A
18	Flexhose w/Shutoff Valve	1	C100009	C100009
19	Thermostat Blower	1	A100014	A100014
20	Face surround	1	W200111P	W200111P
21	Insert Outer Face	1	W200114P	W200114P
22	Safety Screen	1	W200117P	W200117P
23	Optional Remote Control	1	A100001	A100001

### WARNING

Failure to position the parts in accordance with these diagrams or failure to use only parts specifically approved with this appliance may result in property damage or personal injury.

**\* NOTE: The glass frame assembly shall only be replaced as a complete unit as supplied by the manufacturer (Part # A100136).**

---

## TROUBLESHOOTING

---

**WARNING**

Turn appliance OFF and allow to cool before servicing. Only a qualified service person should service and repair the heater.

*Note: All troubleshooting items are listed in order of operation.*

OBSERVED PROBLEM	POSSIBLE CAUSE	REMEDY
Spark ignitor will not light the pilot after repeated pressing of spark ignitor.	<ol style="list-style-type: none"><li>1. Battery needs replacing</li><li>2. Defective ignitor</li><li>3. Misaligned spark electrode</li></ol>	<ol style="list-style-type: none"><li>1. Replace battery</li><li>2. Check connections to ignitor. Replace ignitor if ignitor connections are good, but there is no spark.</li><li>3. Check for spark arcing from the electrode to pilot. Adjust and retighten.</li></ol>
Pilot will not stay lit.	<ol style="list-style-type: none"><li>1. Defective thermocouple. Loose thermocouple</li><li>2. Air in gas line</li><li>3. No gas</li></ol>	<ol style="list-style-type: none"><li>1. Check for proper connection of thermocouple to rear of valve.</li><li>2. Bleed line. Contact dealer</li><li>3. Check shutoff valve and gas supply (LPG tank)</li></ol>
Burner will not light when valve and burner switch are both on.	<ol style="list-style-type: none"><li>1. Defective switch</li><li>2. Defective thermopile</li><li>3. Thermostat set too low/defective</li></ol>	<ol style="list-style-type: none"><li>1. Check switch connections. Jump wires at switch.</li><li>2. Check connections to valve. Contact dealer.</li><li>3. Turn up thermostat to start unit. Check thermostat connections.</li></ol>
Glass fogs up	<ol style="list-style-type: none"><li>1. Normal condition</li></ol>	<ol style="list-style-type: none"><li>1. Allow appliance to warm up. Glass will clear. Additives in the gas may dirty glass. Clean glass when cool.</li></ol>
Blue flames	<ol style="list-style-type: none"><li>1. Normal during start up</li></ol>	<ol style="list-style-type: none"><li>1. Flames will yellow as appliance heats up.</li></ol>
Sooting	<ol style="list-style-type: none"><li>1. Flame impingement</li></ol>	<ol style="list-style-type: none"><li>1. Check stone position. Open shutters to increase primary air.</li></ol>







---

# INSTALLATION RECORDS

---

THE FOLLOWING INFORMATION MUST BE RECORDED BY THE INSTALLER FOR WARRANTY PURPOSES AND FUTURE REFERENCE.

WOODBRIAGE FIREPLACE

Model: \_\_\_\_\_

<p>Name of Owner:</p>  <p>Address:</p>         <p>Phone:</p>	<p>Name of Installer:</p>  <p>Address:</p>         <p>Phone:</p>
<p>Name of Dealer:</p>  <p>Address:</p>         <p>Phone:</p>	



## WARRANTY INFORMATION

THE FOLLOWING INFORMATION MUST BE RECORDED BY THE INSTALLER FOR WARRANTY PURPOSES AND FUTURE REFERENCE.

Always specify model and serial numbers when communicating with the factory.

Model _____	Serial No _____
Purchased From _____	Installed by _____
Date of Purchase _____	Date of Installation _____

### LIFETIME WARRANTY

The following components are warranted for life to the original owner, subject to proof of purchase: Firebox, Combustion Chamber, Heat Exchanger, Grate and Stainless Steel Burners.

### FIVE YEAR WARRANTY

The following components are warranted five (5) years to the original owner, subject of proof of purchase: **Optional Stones.**

### ONE YEAR WARRANTY

The following components are warranted one (1) year, subject of proof of purchase: Thermostat Blower.

Woodbridge Fireplace Inc. warrants the components and materials in your gas appliance to be free from manufacturing and material defects for a period of two years from date of installation. After installation, if any of the components manufactured by Woodbridge Fireplace Inc. in the appliance are found to be defective in materials or workmanship, Woodbridge Fireplace Inc. will, at its option, replace or repair the defective components at no charge to the original owner. Woodbridge Fireplace Inc. will also pay for reasonable labor costs incurred in replacing or repairing such components for a period of two years from date of installation. Any products presented for warranty repair must be accompanied by a dated proof of purchase.

This Limited Lifetime Warranty will be void if the appliance is not installed by a qualified installer in accordance with the installation instructions. The Limited Lifetime Warranty will also be void if the appliance is not operated and maintained according to the operating instructions supplied with the appliance, and does not extend to (1) firebox/burner assembly damage by accident, neglect, misuse, abuse, alterations, negligence of others, including the installation thereof by unqualified installers, (2) the costs of removal, reinstallation or transportation of defective parts on the appliance, or (3) incidental or consequential damage. All service work must be performed by an authorized service representative.

This warranty is expressly in lieu of other warranties, express or implied, including the warranty of merchantability of fitness for purpose and of all other obligations or liabilities. Woodbridge Fireplace Inc. does not assume for it any other obligations or liabilities in connection with sale or use of the appliance. It states that do not allow limitations on how long an implied warranty lasts, or do not allow exclusion of indirect damage, those limitations of exclusions may not apply to you. You may also have additional rights not covered in the Limited Lifetime Warranty.

Woodbridge Fireplace Inc. reserves the right to investigate any and all the claims against the Limited Lifetime Warranty and decide upon method of settlement.

For information about this warranty, contact:

**KEEP THIS FOR WARRANTY**

REV. 11.2018

**Woodbridge Fireplace Inc.**  
**1305 Meyerside Dr., Mississauga**  
**Ontario, Canada L5T 1C9**

**Tel.: 1-905-564-3001**

[www.woodbridgedealer.com](http://www.woodbridgedealer.com)